

**Lipolysis Kits**

Lipolysis plays a central role in the regulation of energy balance. Lipolysis is the process in which triglycerides (TG) are hydrolyzed into glycerol and free fatty acids. This process releases free fatty acids (FFA) into the bloodstream where they may be either re-esterified by the adipocyte or travel to other tissues and exert other effects throughout the body. Elevated adipocyte lipolysis has been observed in obese and diabetic individuals (Arner 1996). Excessive free fatty acid production is believed to contribute to insulin resistance in skeletal muscle that is observed in obesity. Hormone sensitive lipase is the rate-limiting enzyme catalyzing triglyceride

breakdown. Perilipins, one of the PAT (perilipins, adipophilin, TIP47 proteins) family of lipid-associated proteins, are implicated in adipocyte lipolysis by mediating the interaction of HSL with the triacylglycerol molecule (Brasaemle et al. 2004; reviewed in, Tansey et al. 2004.) The presence of these proteins corresponds to lipolytic stimulation in cultured adipocytes (Braemle et al. 2004).

The sympathetic nervous system also plays a key role in the regulation of lipid mobilization. The main lipolytic pathway involves beta-agonists ( $\hat{I}^2$ -agonists), which activate  $\hat{I}^2$ -adrenergic receptors via the intracellular Gs proteins in adipocytes. This leads to the activation of adenylate cyclase (AC), which then increases cyclic AMP (cAMP) levels. Elevated cAMP acts as a second messenger to activate hormone sensitive lipase (HSL). HSL, the rate-limiting enzyme regulating adipocyte lipolysis, then catalyzes the hydrolysis of triglycerides and results in the release of glycerol and FFA (increased lipolysis). Phosphodiesterases (PDE) are enzymes that hydrolyze cAMP to 5'AMP (5 prime adenosine monophosphate). This action results in a decrease in lipolysis. PDE inhibitors increase intracellular cAMP levels. 3-isobutyl-1-methylxanthine (IBMX), a non-specific inhibitor of cAMP phosphodiesterases (PDE), is used as the positive control if your test compounds are suspected PDE inhibitors. Isoproterenol, a non-specific  $\hat{I}^2$ -adrenergic agonist is used as the positive control if your test compounds affect lipolysis via  $\hat{I}^2$ -adrenergic receptors (Robidoux et al. 2004).

Our lipolysis assay kits provide the tool to study chemical compounds that may influence lipolysis in cultured human or 3T3-L1 adipocytes. Kits are available with and without a plate of cells. Kits can measure the glycerol and/or free fatty acids released in lipolysis.

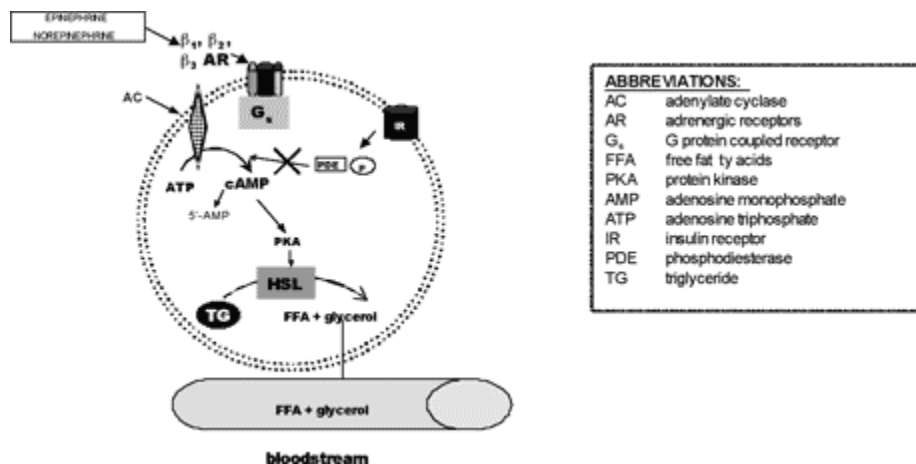
**Overview of adipocyte lipolysis**

India Contact:

**Life Technologies (India) Pvt. Ltd.**

306, Aggarwal City Mall, Opposite M2K Pitampura, Delhi – 110034 (INDIA). Ph: +91-11-42208000, 42208111, 42208222, Mobile: +91-9810521400, Fax: +91-11-42208444

Email: [customerservice@lifetechindia.com](mailto:customerservice@lifetechindia.com) Website: [www.lifetechindia.com](http://www.lifetechindia.com)

**Ordering Information:****Human Lipolysis Assay Kits**

Item	Unit	Catalog#
Lipolysis Assay KIT, Glycerol Detection ( REAGENTS + CELLS)	KIT	LIP-1
Lipolysis Assay KIT , Glycerol Detection (REAGENTS ONLY)	KIT	LIP-1-NC
Lipolysis Assay KIT (5 plates; REAGENTS + BUFFERS ONLY)	KIT	LIP-1-RB
Lipolysis Assay KIT, Free fatty acids Detection (REAGENTS + CELLS)	KIT	LIP-2
Lipolysis Assay KIT, Free fatty acids Detection (REAGENTS ONLY)	KIT	LIP-2-NC
Lipolysis Assay KIT, Free Fatty Acids Detection (5 plates; REAGENTS + BUFFERS ONLY)	KIT	LIP-2-RB
Lipolysis Assay KIT, Free Fatty Acids Detection-Automation Screening KIT, REAGENTS ONLY	KIT	LIP-2-SCRN
Lipolysis Assay KIT Dual glycerol and free fatty acids Detection (REAGENTS + CELLS)	KIT	LIP-3
Lipolysis Assay KIT , Dual Glycerol and free fatty acids Detection (REAGENTS ONLY)	KIT	LIP-3-NC
Lipolysis Assay KIT, Dual Glycerol and free fatty acids Detection (REAGENTS ONLY for 5-96 well plates)	KIT	LIP-3-RB
Lipolysis Assay KIT, Dual Glycerol and free fatty acids Detection, Omental Cells (REAGENTS + CELLS), 100-points	KIT	LIP-3-OM
Lipolysis Assay KIT, Glycerol Detection, Fluorescent (REAGENTS + CELLS)	KIT	LIP-4
Lipolysis Assay KIT, Glycerol Detection, Fluorescent (REAGENTS ONLY)	KIT	LIP-4-NC
Glycerol Standard, for Lipolysis Assay Kits	EACH	LIP-GLYSTAN

**3T3-L1**

Item	Unit	Catalog#
3T3-L1 Lipolysis Assay Kit (glycerol detection; REAGENTS + CELLS)*	Kit	LIP-1-L1
3T3-L1 Lipolysis Assay Kit (glycerol detection; REAGENTS ONLY)	Kit	LIP-1-NCL1
3T3-L1 Lipolysis Assay Kit (free fatty accids detection; REAGENTS + CELLS)*	Kit	LIP-2-L1
3T3-L1 Lipolysis Assay Kit (free fatty acids detection; REAGENTS ONLY)	Kit	LIP-2-NCL1
3T3-L1 Lipolysis Assay Kit (dual glycerol and free fatty acids detection; REAGENTS + CELLS)*	Kit	LIP-3-L1
3T3-L1 Lipolysis Assay Kit (dual glycerol and free fatty acids detection; REAGENTS ONLY)	Kit	LIP-3-NCL1

- This kit includes one 96-well plate of 3T3-L1 preadipocytes, media to differentiate the cells and reagents for the detection of lipolysis.

**India Contact:****Life Technologies (India) Pvt. Ltd.**

306, Aggarwal City Mall, Opposite M2K Pitampura, Delhi – 110034 (INDIA). Ph: +91-11-42208000, 42208111, 42208222, Mobile: +91-9810521400, Fax: +91-11-42208444  
 Email: [customerservice@lifetechindia.com](mailto:customerservice@lifetechindia.com) Website: [www.lifetechindia.com](http://www.lifetechindia.com)