

Azoxystrobin ELISA (Microtiter Plate)

Enzyme-Linked Immunosorbent Assay for the Determination
of Azoxystrobin in Water and Wine Samples

Product No. 500701

Importance of Azoxystrobin Determination

Azoxystrobin is a broad-spectrum fungicide which is effective against the four major groups of fungal diseases: *Ascomycetes*, *Basidiomycetes*, *Deuteromycetes*, and *Oomycetes*. It is used worldwide in both agricultural (cereal grains, fruits, vegetables) and non-agricultural settings (flowers, grass).

Humans may be exposed to Azoxystrobin through direct physical contact with treated plants or ingestion of contaminated foods or drinking water. Drinking water sources can be contaminated through run-off (surface water) or leaching (ground water); a groundwater advisory appears on Azoxystrobin products due to this potential for leaching. The U.S. EPA lists Azoxystrobin as a compound which is moderately persistent in soil. In humans, Azoxystrobin is an irritant to skin. Azoxystrobin is very toxic to aquatic organisms and to some plant species including Macintosh apple trees and other apple trees which are derived from Macintosh. Crabapple trees are also damaged by exposure to Azoxystrobin.

Due to the widespread use of Azoxystrobin on plants meant for human consumption, many countries have established Acceptable Daily Intake (ADI) levels. The European Union has established an ADI of 0.2 mg/kg of body weight. Australia has established an ADI of 0.1 mg/kg of body weight. Many countries have also established regulatory limits on the levels of chemical residues on many individual foods. These levels vary depending on country and food type.* For example, the European Union (EU) has established a maximum residue limit (MRL) of Azoxystrobin for dried beans and peas at 0.1 mg/kg, while the United States (US) has placed the limit at 0.5 mg/kg. Many foods and drinks have no established MRL. For example, although grapes have an Azoxystrobin MRL of 2.0 mg/kg in both the EU and the US, no MRL has been established for products made from grapes such as wine. Pesticide content in wine has become an area of concern, as grapes are one of the most highly pesticide treated foods. A study by the French Ministry of Agriculture showed the transfer of pesticides from contaminated grapes to the wine produced from it; contamination with Azoxystrobin was found in approximately 90% of wines produced from grapes containing measurable levels of Azoxystrobin.^Δ A study released in 2008 evaluating the levels of pesticides in wine purchased in the European Union found that all conventional (non-organic) wines tested contained pesticides (a total of 24 different pesticides and as many as 10 different pesticides in one bottle); Azoxystrobin was found in 18% of the conventional wines tested.[‡]

*For listings of foods for which MRLs have been established: for the European Union, search "Official Journal of the European Union Commission Regulation (EU) No 270/2012 of 26 March 2012" and for the United States, go to www.federalregister.gov then search "Azoxystrobin; Pesticide Tolerances."

^ΔFor full text of study, see Cugier et al. "Plan de surveillance résidus en Viticulture (Campagnes viticoles 1990-2003)", Direction Générale de l'Alimentation, Ministère de l'Agriculture, de l'Alimentation, de la Pêche et de la Ruralité (2005).

[‡]For full text of study, search "Pesticide Action Network Europe Message in a Bottle."

The Azoxystrobin ELISA allows for the analysis of 42 samples in duplicate determination. Less than 1 mL of sample is required. The test can be performed in less than 2 hours.

Performance Data

Test sensitivity: The limit of quantitation for Azoxystrobin (90% B/B₀ calculated from the average of 23 calibration curves) is approximately 0.009 ng/mL. The middle of the test (50% B/B₀ calculated from the average of 23 calibration curves) is approximately 0.054 ng/mL. Determinations closer to the middle of the calibration curve give the most accurate results.

Test reproducibility: Coefficients of variation (CVs) for standards: <10%; CVs for samples: <15%.

Standard Curve:

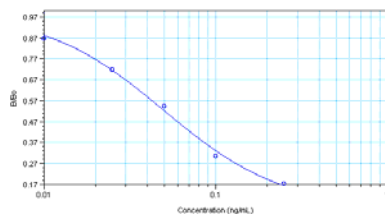

For demonstration purposes only. Not for use in sample interpretation.

General Limited Warranty: Abraxis LLC warrants the products manufactured by the Company, against defects and workmanship when used in accordance with the applicable instructions for a period not to extend beyond the product's printed expiration date. **Abraxis makes no other warranty, expressed or implied. There is no warranty of merchantability or fitness for a particular purpose.**

Spanish National Research Council (CSIC) and the University of Valencia.

The monoclonal antibody and HRP conjugate included in this kit has been licensed from the

For ordering or technical assistance contact: India Contact:

Life Technologies (India) Pvt. Ltd.

306, Aggarwal City Mall, Road No. 44, Pitampura, Delhi - 110034, India

Mobile: +91-98105-21400, Tel: +91-11-42208000, 8111, 8222, Fax: +91-11-42208444

Email: customerservice@lifetechindia.com, www.atzllabs.com; www.lifetechindia.com

1. General Description

The Abraxis Azoxystrobin ELISA is an immunoassay for the quantitative and sensitive screening of Azoxystrobin. This test is suitable for the quantitative and/or qualitative screening of Azoxystrobin in water or wine samples. Samples requiring regulatory action should be confirmed by HPLC, GC/MS, or other conventional methods.

2. Safety Instructions

The standard solutions in the test kit contain small amounts of Azoxystrobin. The substrate solution contains tetramethylbenzidine (TMB) and the stop solution contains diluted sulfuric acid. Avoid contact of the TMB and stopping solution with skin and mucous membranes. If these reagents come in contact with skin, wash with water.

3. Storage and Stability

The Azoxystrobin ELISA should be stored in the refrigerator (4–8°C). The solutions must be allowed to reach room temperature (20–25°C) before use. Reagents may be used until the expiration date on the box.

4. Test Principle

The test is a direct competitive ELISA based on the recognition of Azoxystrobin by specific antibodies. Azoxystrobin, when present in a sample, and an Azoxystrobin-HRP analogue compete for the binding sites of the mouse anti-Azoxystrobin antibodies in solution. The Azoxystrobin antibodies are then bound by a second antibody (goat anti-mouse) immobilized on the wells of the microtiter plate. After a washing step and addition of the substrate solution, a color signal is generated. The intensity of the blue color is inversely proportional to the concentration of Azoxystrobin present in the sample. The color reaction is stopped after a specified time and the color is evaluated using an ELISA reader. The concentrations of the samples are determined by interpolation using the standard curve constructed with each run.

5. Limitations of the Azoxystrobin ELISA, Possible Test Interference

Although many organic and inorganic compounds commonly found in samples have been tested and found not to interfere with this test, due to the high variability of compounds that might be found in samples, test interferences caused by matrix effects cannot be completely excluded.

The presence of the following substances were found to have no significant effect on the Azoxystrobin assay results: calcium sulfate, magnesium sulfate, sodium chloride, magnesium chloride, sodium nitrate, potassium phosphate, sodium thiosulfate, and aluminum oxide up to 10,000 ppm; calcium chloride, copper chloride, manganese sulfate, sodium fluoride, ferric sulfate, and zinc sulfate up to 1,000 ppm; humic acid up to 100 ppm.

Samples containing methanol must be diluted to a concentration ≤ 10% methanol to avoid matrix effects.

Mistakes in handling the test can cause errors. Possible sources for such errors include: inadequate storage conditions of the test kit, incorrect pipetting sequence or inaccurate volumes of the reagents, too long or too short incubation times during the immune and/or substrate reaction, extreme temperatures (lower than 10°C or higher than 30°C) during the test performance.

The Abraxis Azoxystrobin ELISA kit provides screening results. As with any analytical technique (GC, HPLC, etc.), samples requiring some regulatory action should be confirmed by an alternative method.

A. Reagents and Materials Provided

1. Microtiter plate (12 X 8 strips) coated with a secondary antibody, in a resealable aluminum pouch
2. Azoxystrobin Calibrators/Standards (6): 0, 0.01, 0.025, 0.05, 0.10, 0.25 ng/mL (ppb), 1 mL each
3. Antibody Solution (mouse anti-Azoxystrobin), 6 mL
4. Azoxystrobin-HRP Conjugate Solution, 6 mL
5. Wash Solution (5X) Concentrate, 100 mL, must be diluted before use, see Test Preparation (Section C)
6. Sample Diluent, 25 mL
7. Substrate (Color) Solution (TMB), 16 mL
8. Stop Solution, 12 mL (handle with care)

B. Additional Materials (not delivered with the test kit)

1. Micro-pipettes with disposable plastic tips (50-200 μ L)
2. Multi-channel pipette (50-250 μ L) or stepper pipette with disposable plastic tips (50-250 μ L)
3. Microtiter plate reader (wave length 450 nm)
4. Container with 500 mL capacity (for 1X diluted wash solution, see Test Preparation, Section C)
5. Deionized or distilled water
6. Methanol
7. Glass vials with Teflon lined caps
8. Paper towels or equivalent absorbent material
9. Timer
10. Tape or parafilm

C. Test Preparation

Micro-pipetting equipment and pipette tips for pipetting the standards and the samples are necessary. In order to equalize the incubation periods on the entire microtiter plate, a multi-channel pipette or a stepping pipette is recommended for adding the enzyme conjugate, antibody, substrate, and stop solutions. Please only use the reagents and standards from one package lot in one test, as they have been adjusted in combination.

1. Allow the microtiter plate, reagents, and samples to reach room temperature before use.
2. Remove the number of microtiter plate strips required from the aluminum pouch. The remaining strips are stored in the aluminum pouch with the desiccant (tightly sealed) in the refrigerator (4-8°C).
3. The standard solutions, conjugate, antibody, substrate and stop solutions are ready to use and do not require any further dilutions.
4. Dilute the Wash Solution (5X) Concentrate at a ratio of 1:5. If using the entire bottle (100 mL), add to 400 mL of deionized or distilled water and mix thoroughly.
5. The stop solution must be handled with care as it contains diluted H₂SO₄.

D. Sample Preparation

Water Samples

Water samples should be collected in glass sample containers. Immediately upon collection, water samples should be preserved with methanol at a ratio of 1 mL of methanol per 9 mL of water. For example, a 9.0 mL sample of water added to a sample container should have 1.0 mL of methanol added.

The Azoxystrobin concentration contained in water samples is determined by multiplying the ELISA result by the dilution factor of 1.1. Highly contaminated samples (those outside of the calibration range of the assay) must be diluted further in sample diluent and re-analyzed.

Wine Samples

In order to eliminate matrix interferences, wine samples must be diluted in deionized or distilled water prior to analysis:

1. Add 10 mL of deionized or distilled water to an appropriately labeled glass vial.
2. Add 25 μ L of wine sample to the vial.
3. Vortex thoroughly.
4. Diluted sample is ready to analyze (Assay Procedure, step 1).

The Azoxystrobin concentration contained in wine samples is determined by multiplying the ELISA result by the dilution factor of 400. Highly contaminated samples (those outside of the calibration range of the assay) must be diluted further in deionized or distilled water and re-analyzed.

E. Working Scheme

The microtiter plate consists of 12 strips of 8 wells, which can be used individually for the test. The standards must be run with each test. Never use the values of standards which have been determined in a test performed previously.

	1	2	3	4	5	6	7	8	9	10	11	12
A	Std 0	Std 4	etc.									
B	Std 0	Std 4	etc.									
C	Std 1	Std 5										
D	Std 1	Std 5										
E	Std 2	Samp1										
F	Std 2	Samp1										
G	Std 3	Samp2										
H	Std 3	Samp2										

Std 0-Std 5: Standards

(0; 0.01; 0.025; 0.05; 0.1; 0.25 ppb)

Samp1, Samp2, etc.: Samples

F. Assay Procedure

1. Add 50 μ L of the calibrator/standard solutions or samples into the wells of the test strips according to the working scheme given. Analysis in duplicate or triplicate is recommended.
2. Add 50 μ L of antibody solution to the individual wells successively using a multi-channel pipette or a stepping pipette. Cover the wells with parafilm or tape and mix the contents by moving the strip holder in a circular motion on the benchtop for 30 seconds. Be careful not to spill the contents. Incubate the strips for 30 minutes at room temperature.
3. Add 50 μ L of conjugate solution to the individual wells successively using a multi-channel pipette or a stepping pipette. Cover the wells with parafilm or tape and mix the contents by moving the strip holder in a circular motion on the benchtop for 30 seconds. Be careful not to spill the contents. Incubate the strips for 30 minutes at room temperature.
4. Remove the covering and decant the contents of the wells into a sink. Wash the strips three times using the diluted washing buffer solution. Please use at least a volume of 250 μ L of washing buffer for each well in each washing step. Remaining buffer in the wells should be removed by patting the inverted plate dry on a stack of paper towels.
5. Add 150 μ L of substrate (color) solution to the wells successively using a multi-channel pipette or a stepping pipette. Cover the wells with parafilm or tape and mix the contents by moving the strip holder in a circular motion on the benchtop for 30 seconds. Be careful not to spill the contents. Incubate the strips for 20 minutes at room temperature. Protect the strips from direct sunlight.
6. Add 100 μ L of stop solution to the wells in the same sequence as for the substrate solution.
7. Read the absorbance at 450 nm using a microplate ELISA photometer within 15 minutes after the addition of stopping solution.

G. Evaluation

The evaluation of the ELISA can be performed using commercial ELISA evaluation programs such as 4-Parameter (preferred) or Logit/Log. For a manual evaluation, calculate the mean absorbance value for each of the standards. Calculate the %B/B₀ for each standard by dividing the mean absorbance value for each standard by the Zero Standard (Standard 0) mean absorbance. Construct a standard curve by plotting the %B/B₀ for each standard on the vertical linear (y) axis versus the corresponding Azoxystrobin concentration on the horizontal logarithmic (x) axis on graph paper. %B/B₀ for samples will then yield levels in ppb (or ng/mL) of Azoxystrobin by interpolation using the standard curve; results for water samples are determined by multiplying the concentration determined from the curve by the dilution factor of 1.1, results for wine samples are determined by multiplying the concentration determined from the curve by the dilution factor of 400. Samples showing lower concentrations of Azoxystrobin than standard 1 (0.01 ppb) should be reported as containing < 0.011 ppb of Azoxystrobin for water samples or < 4 ppb for wine samples. Samples showing a higher concentration than standard 5 (0.25 ppb) should be reported as containing > 0.275 ppb for water samples or > 100 ppb for wine samples. If a quantitative result is necessary, samples must be diluted further with the appropriate sample diluent and re-analyzed.

Azoxystrobin Plate, Detailed ELISA Procedure

1. Addition of Standards, Samples

Add 50 μ L of the standard solutions or samples into the wells of the test strips according to the working scheme given. We recommend using duplicates or triplicates.

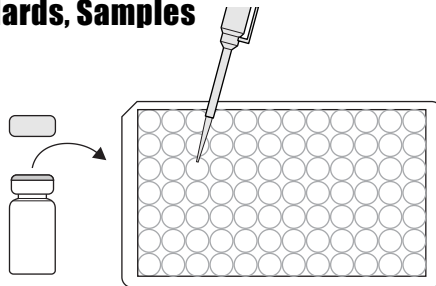

2. Addition of Antibody Solution

Add 50 μ L of the Azoxystrobin antibody solution to the individual wells successively using a multi-channel pipette. Cover the wells with parafilm or tape and mix the contents by moving the strip holder in a rapid circular motion on the benchtop. Be careful not to spill contents. Incubate the strips for 30 minutes at room temperature.

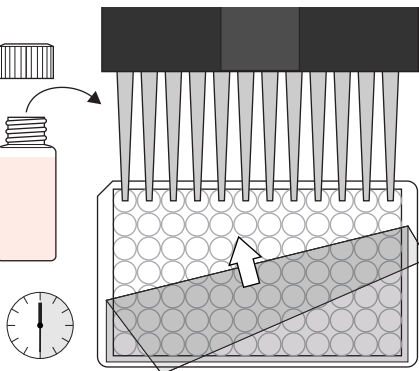

3. Addition of Enzyme Conjugate

Add 50 μ L of the enzyme conjugate to the individual wells successively using a multi-channel pipette or a stepping pipette. Cover the wells with parafilm or tape and mix the contents by moving the strip holder in a rapid circular motion on the benchtop. Be careful not to spill contents. Incubate the strips for 30 minutes at room temperature.

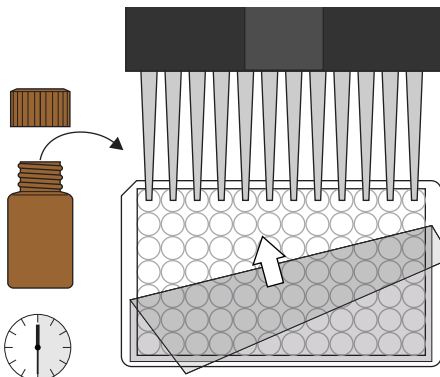

4. Washing of Plates

After incubation, remove the covering and vigorously shake the contents of the wells into a sink. Wash the strips three times with a multi-channel pipette or wash bottle using the diluted 1X washing buffer solution. Please use at least a volume of 250 μ L of washing buffer for each well and each washing step. Remaining buffer in the wells should be removed by patting the plate dry on a stack of paper towels.

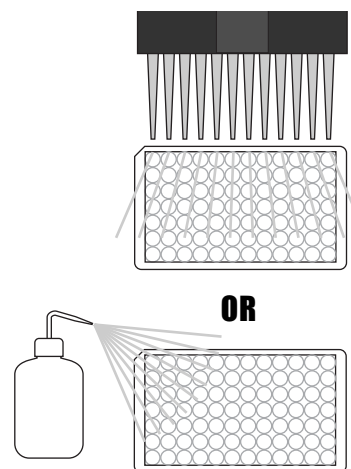

5. Addition of Substrate/Color Solution

Add 150 μ L of substrate/color solution to the individual wells successively using a multi-channel pipette or a stepping pipette. Cover the wells with parafilm or tape and mix the contents by moving the strip holder in a rapid circular motion on the benchtop. Be careful not to spill contents. Incubate the strips for 20 minutes at room temperature.

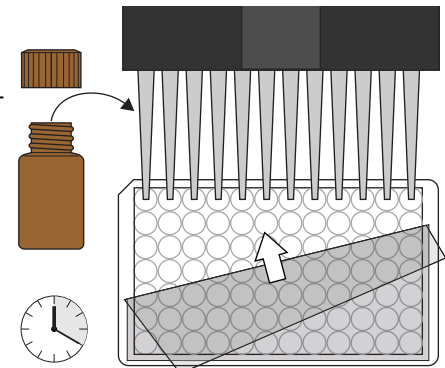

6. Addition of Stopping Solution

Add 100 μ L of stop solution to the wells in the same sequence as for the substrate solution using a multi-channel pipette or a stepping pipette.

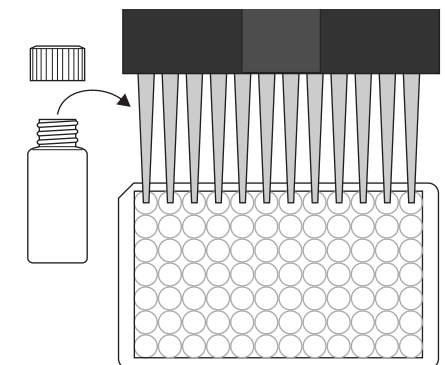

7. Measurement of Color

Read the absorbance at 450 nm using a microplate ELISA reader. Calculate results.

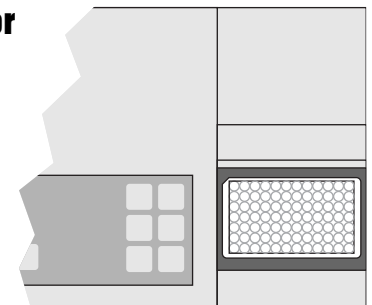

India Contact:

Life Technologies (India) Pvt. Ltd.

306, Aggarwal City Mall, Road No. 44, Pitampura, Delhi - 110034, India
Mobile: +91-98105-21400, Tel: +91-11-42208000, 8111, 8222, Fax: +91-11-42208444
Email: customerservice@lifetechindia.com, www.atzlabs.com; www.lifetechindia.com

Azoxystrobin Plate, Concise ELISA Procedure

1. Addition of Standards, Samples

Add 50 μ L of standard solutions or samples.

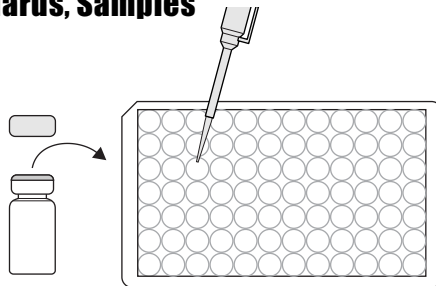

2. Addition of Antibody Solution

Add 50 μ L of the antibody solution. Cover and mix for 30 seconds by rotating on benchtop. Incubate for 30 minutes at room temperature.

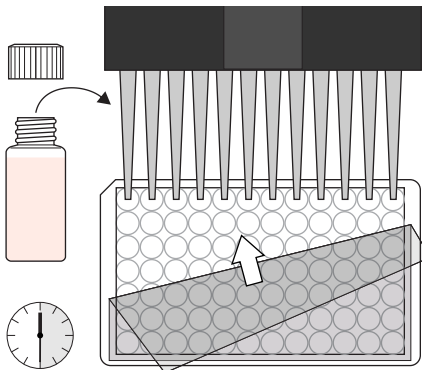

3. Addition of Enzyme Conjugate

Add 50 μ L of enzyme conjugate. Cover and mix for 30 seconds by rotating on benchtop. Incubate for 30 minutes at room temperature.

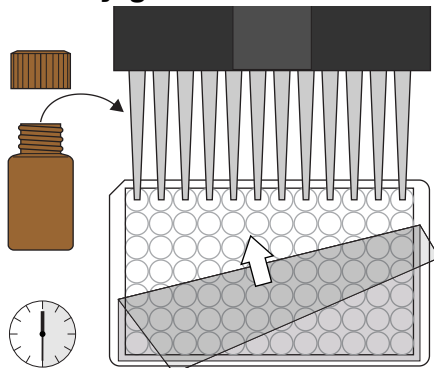

4. Washing of Plates

Wash the plates three times with 250 μ L of diluted 1X washing buffer.

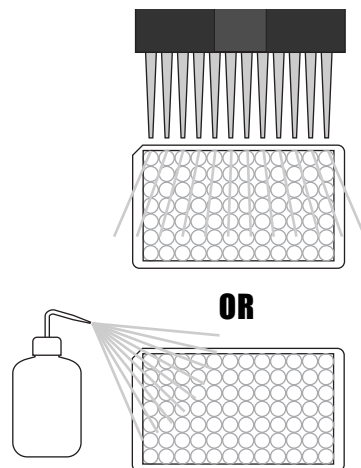

5. Addition of Substrate/Color Solution

Add 150 μ L of substrate/color solution. Incubate 20 minutes at room temperature and away from direct sunlight.

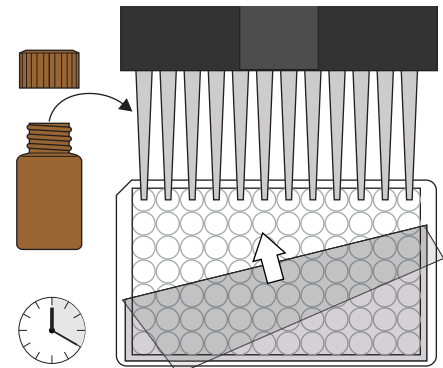

6. Addition of Stopping Solution

Add 100 μ L of stop solution.

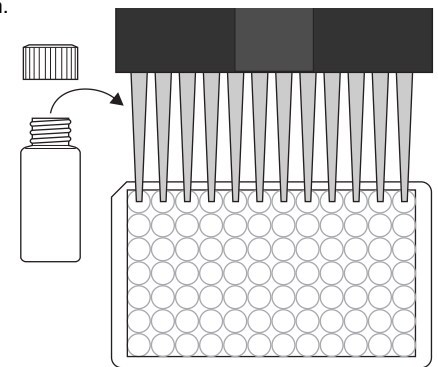

7. Measurement of Color

Measure color at 450 nm. Calculate results.

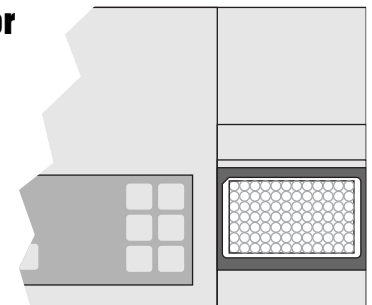

India Contact:

Life Technologies (India) Pvt. Ltd.

306, Aggarwal City Mall, Road No. 44, Pitampura, Delhi - 110034, India
Mobile: +91-98105-21400, Tel: +91-11-42208000, 8111, 8222, Fax: +91-11-42208444
Email: customerservice@lifetechindia.com, www.atzlabs.com; www.lifetechindia.com

Safety Data Sheet

Section 1: Product and Company Identification

1.1 Product Identifiers:

Product Name: Azoxystrobin Plate Kit

Product Code: 500701

1.2 Identified Use: Determination of Azoxystrobin in samples. **Restrictions on Use:** For research use only.

1.3 Company: Abraxis, Inc., 124 Railroad Drive, Warminster, PA 18974 USA, info@abraxiskits.com +1(215) 357-3911, FAX +1(215) 357-5232

1.4 Emergency Telephone Number: +1(215) 357-3911

Section 2: Hazard(s) Identification

2.1 Classification of the mixture:

GHS Classification in accordance with 29 CFR 1910 (OSHA HCS)

Flammable liquids (Category 2), H225 Highly flammable liquid and vapor

Acute toxicity, Oral (Category 3), H301 Toxic if swallowed

Acute toxicity, Inhalation (Category 3), H331 Toxic if inhaled

Acute toxicity, Dermal (Category 3), H311 Toxic in contact with skin

Specific target organ toxicity - single exposure (Category 1), H370 Causes damage to organs

HMIS Rating: Health hazard: 2, Chronic Health Hazard: *, Flammability: 3, Physical Hazard 0

NFPA Rating: Health hazard: 2, Fire Hazard: 3, Reactivity Hazard: 0

2.2 GHS Label elements, including precautionary statements:

Pictogram(s)



Signal word: Danger

Hazard statement(s):

H225 Highly flammable liquid and vapor.

H301 + H311 + H331 Toxic if swallowed, in contact with skin, or if inhaled

H370 Causes damage to organs.

Precautionary statement(s):

P210 Keep away from heat/sparks/open flames/hot surfaces. No smoking.

P233 Keep container tightly closed.

P240 Ground/bond container and receiving equipment.

P241 Use explosion-proof electrical/ventilating/lighting equipment.

P242 Use only non-sparking tools.

P243 Take precautionary measures against static discharge.

P260 Do not breathe dust/fume/gas/mist/vapors/ spray.

P264 Wash skin thoroughly after handling.

P270 Do not eat, drink or smoke when using this product.

P271 Use only outdoors or in a well-ventilated area.

P280 Wear protective gloves/eye protection/face protection.

P301 + P310 + P330 IF SWALLOWED: Immediately call a POISON CENTER or doctor/physician. Rinse mouth.

P303 + P361 + P353 IF ON SKIN (or hair): Take off immediately all contaminated clothing. Rinse skin with water/shower.

P304 + P340 + P311 IF INHALED: Remove person to fresh air and keep comfortable for breathing. Call a POISON CENTER or doctor/physician.

P307 + P311 If exposed: Call a POISON CENTER or doctor/physician.

P362 Take off contaminated clothing and wash before reuse.

P370 + P378 In case of fire: Use dry sand, dry chemical or alcohol-resistant foam to extinguish.

P403 + P233 Store in a well-ventilated place. Keep container tightly closed.

P403 + P235 Store in a well-ventilated place. Keep cool.

P405 Store locked up.

P501 Dispose of contents/ container to an approved waste disposal plant.

2.3 Hazards not otherwise classified (HNOC) or not covered by GHS: None known.

2.4 Unknown acute toxicity: None known.

Section 3: Composition / Information on Ingredients

3.2 Mixtures: Mixture of the hazardous substance(s) listed below, with nonhazardous additions.

Hazardous component(s):

Name and Synonym(s): Methyl alcohol, MeOH, Methanol Formula: CH₄O Molecular weight: 32.04 g/mol

CAS No.: 67-56-1 EC-No.: 200-659-6

Classification: Flammable Liquid 2, Acute Toxicity 3; STOT SE 1; H225, H301 + H311 + H331, H370

Percentage in Mixture: 1.8 %

For full text of H-Statements mentioned in this Section, see Section 2.

Section 4: First Aid Measures

4.1 Description of first aid measures: Consult a physician. Show this safety data sheet to the doctor in attendance. Move out of dangerous area.

If inhaled: If breathed in, move person into fresh air. If not breathing, give artificial respiration. Consult a physician.

In case of skin contact: Wash off with soap and plenty of water. Take victim immediately to hospital. Consult a physician.

In case of eye contact: Rinse thoroughly with plenty of water for at least 15 minutes and consult a physician.

If swallowed: Do NOT induce vomiting. Never give anything by mouth to an unconscious person. Rinse mouth with water. Consult a physician.

4.2 Most important symptoms and effects, both acute and delayed: The most important known symptoms and effects are described in the labelling (see section 2.2) and/or in section 11

4.3 Indication of any immediate medical attention and special treatment needed: No data available. Treat symptomatically.

Section 5: Fire-fighting Measures

5.1 Suitable extinguishing media: Dry powder or sand

Unsuitable extinguishing media: Do NOT use water jet

5.2 Special hazards arising from the substance or mixture: Carbon oxides

5.3 Advice for firefighters: Wear self-contained breathing apparatus for fire-fighting if necessary.

5.4 Further information: Use water spray to cool unopened containers.

Section 6: Accidental Release Measures

6.1 Personal precautions, protective equipment and emergency procedures: Use personal protective equipment (see section 8). Avoid dust formation. Avoid breathing vapors, mist, dust, or gas. Ensure adequate ventilation. Remove all sources of ignition. Evacuate personnel to safe areas.

6.2 Environmental precautions: Prevent further leakage or spillage if safe to do so. Do not let product enter drains. Discharge into the environment must be avoided.

6.3 Methods and materials for containment and cleaning up: Contain spillage. Solids (if applicable): Pick up and arrange disposal without creating dust. Sweep up and shovel. Liquids (if applicable): Absorb with non-combustible liquid-binding material (sand, earth, diatomite, vermiculite). Keep in suitable, closed containers for disposal.

6.4 Reference to other sections: For information on safe handling see section 7.

For information on personal protection see section 8.

For information on disposal see section 13.

Section 7: Handling and Storage

7.1 Precautions for safe handling: See section 2. Avoid inhalation of vapors or mist, and avoid contact with skin and eyes. Wear appropriate personal protective equipment. Use explosion-proof equipment. Keep away from sources of ignition. Do not eat, drink, or smoke in work area. Take measures to prevent the buildup of electrostatic charge.

7.2 Precautions for safe storage: Keep container(s) tightly closed in a dry, well-ventilated place. Protect from physical damage. Opened containers must be carefully resealed and kept upright to prevent leakage. See label or product insert for appropriate storage temperature and additional specific information. Storage class (TRGS 510): Flammable liquids.

7.3 Specific end use(s): Other than use(s) specified in section 1, no other uses are stipulated.

Section 8: Exposure Controls / Personal Protection

8.1 Control parameters:

Component(s) with workplace control parameters

Methanol, CAS No. 67-56-1

Value	Control parameters	Basis
TWA	200.000000 ppm	USA. ACGIH Threshold Limit Values (TLV)
Headache Nausea Dizziness Eye damage		

Substances for which there is a Biological Exposure Index or Indices (see BEI section) Danger of cutaneous absorption		
STEL	250.000000 ppm	USA. ACGIH Threshold Limit Values (TLV)
Headache Nausea Dizziness Eye damage Substances for which there is a Biological Exposure Index or Indices (see BEI section) Danger of cutaneous absorption		
TWA	200.000000 ppm; 260.000000 mg/m ³	USA. NIOSH Recommended Exposure Limits
Potential for dermal absorption		
ST	250.000000 ppm; 325.000000 mg/m ³	USA. NIOSH Recommended Exposure Limits
Potential for dermal absorption		
TWA	200.000000 ppm; 260.000000 mg/m ³	USA. Occupational Exposure Limits; (OSHA) - Table Z-1 Limits for Air Contaminants
The value in mg/m ³ is approximate		
TWA	200 ppm; 260 mg/m ³	USA. NIOSH Recommended Exposure Limits
Potential for dermal absorption		
ST	250 ppm; 325 mg/m ³	USA. NIOSH Recommended Exposure Limits
Potential for dermal absorption		
TWA	200 ppm; 260 mg/m ³	USA. Occupational Exposure Limits; (OSHA) - Table Z-1 Limits for Air Contaminants
The value in mg/m ³ is approximate		
STEL	250 ppm; 325 mg/m ³	USA. OSHA - TABLE Z-1 Limits for Air Contaminants - 1910.1000
Skin notation		
TWA	200 ppm; 260 mg/m ³	USA. OSHA - TABLE Z-1 Limits for Air Contaminants - 1910.1000
Skin notation		

Biological occupational exposure limits

Methanol, CAS No. 67-56-1

Parameters	Value	Biological specimen	Basis
Methanol	15.0000 mg/l	Urine	ACGIH – Biological Exposure Indices (BEI)
End of shift (As soon as possible after exposure ceases)			

Derived No Effect Level (DNEL)

Methanol, CAS No. 67-56-1

Application area	Exposure routes	Health effect	Value
Workers	Skin contact	Long-term systemic effects, Acute systemic effects	40mg/kg BW/d
Consumers	Skin contact	Long-term systemic effects, Acute systemic effects	8mg/kg BW/d
Consumers	Ingestion	Long-term systemic effects, Acute systemic effects	8mg/kg BW/d
Workers	Inhalation	Acute systemic effects, Acute local effects, Long-term systemic effects, Long-term local effects	260 mg/m ³
Consumers	Inhalation	Acute systemic effects, Acute local effects, Long-term systemic effects, Long-term local effects	50 mg/m ³

Predicted No Effect Concentration (PNEC)

Methanol, CAS No. 67-56-1

Compartment	Value
Soil	23.5 mg/kg
Marine water	15.4 mg/l
Fresh water	154 mg/l
Fresh water sediment	570.4 mg/kg
Onsite sewage treatment plant	100 mg/kg

8.2 Exposure controls:

Appropriate engineering controls: Provide adequate ventilation. Handle in accordance with good industrial hygiene and safety practice. Wash hands before breaks and at the end of workday. Keep away from food and beverages.

Personal protective equipment

Eye protection: Use equipment for eye protection tested and approved under appropriate government standards such as NIOSH (US) or EN 166 (EU).

Skin protection: Handle with chemical resistant gloves. Gloves must be inspected prior to use. Use proper glove removal technique (without touching glove's outer surface) to avoid skin contact with this product. Dispose of contaminated gloves after use in accordance with applicable laws and good laboratory practices. Wash and dry hands.

Respiratory protection: Use a chemical fume hood or approved respiratory protection equipment.

Body protection: Lightweight, protective clothing to prevent skin exposure.

Section 9: Physical and Chemical Properties

9.1 Information on basic physical and chemical properties of mixture

Appearance: Multiple

Odor: Characteristic

Odor Threshold: No data available

pH: Multiple

Melting point/freezing point: No data available

Initial boiling point and boiling range: No data available

Flash point: No data available

Evaporation rate: No data available

Flammability (solid, gas): No data available

Upper/lower flammability or explosive limits: No data available

Vapor pressure: No data available

Vapor density: No data available

Relative density: No data available

Water solubility: Various

Partition coefficient: n-octanol/water: No data available

Auto-ignition temperature: Not applicable

Decomposition temperature: No data available

Viscosity: No data available

Explosive properties: No data available

Oxidizing properties: No data available

9.2 Other information: No data available

Section 10: Stability and Reactivity

10.1 Reactivity: No data available

10.2 Chemical stability: Stable under recommended storage conditions.

10.3 Possibility of hazardous reactions: No data available

10.4 Conditions to avoid: Keep away from open flame, hot surfaces, heat sources, and sources of ignition.

10.5 Incompatible materials: Acid chlorides, acid anhydrides, strong oxidizing agents, alkali metals, reducing agents, acids, peroxides

10.6 Hazardous decomposition products: No data available. In the event of fire: see section 5.

Section 11: Toxicological Information

11.1 Information on toxicological effects

To the best of our knowledge, the chemical, physical, and toxicological properties of this product have not been thoroughly investigated.

Acute toxicity (Methanol, CAS No. 67-56-1):

Inhalation LC50 Inhalation - Rat - 4 h - 128.2 mg/l; LC50 Inhalation - Rat - 6 h - 87.6 mg/l; LD50 Dermal - Rabbit - 17,100 mg/kg

Ingestion LDLO Oral - Human - 143 mg/kg (Lungs, Thorax, or Respiration:Dyspnea. Ingestion may cause gastrointestinal irritation, nausea, vomiting and diarrhea); LD50 Oral - Rat - 1,187 - 2,769 mg/kg

Skin contact Rabbit skin—no irritation

Eye contact Rabbit eye—no irritation

Respiratory or skin sensitization Maximization Test (GPMT)(OECD Test Guideline 406)--Guinea pig--does not cause skin sensitization

Aspiration hazard No data available

Mutagenicity (Methanol, CAS No. 67-56-1): Ames test (*S. typhimurium*)--Result: negative; *in vitro* assay (fibroblasts)--Result: negative; *in vivo* mammalian bone-marrow cytogenetic test, chromosomal analysis (mouse, male and female)--Result: negative

Carcinogenicity:

IARC: No component of this product present at levels greater than or equal to 0.1% is identified as probable, possible or confirmed human carcinogen by IARC.

ACGIH: No component of this product present at levels greater than or equal to 0.1% is identified as a carcinogen or potential carcinogen by ACGIH.

NTP: No component of this product present at levels greater than or equal to 0.1% is identified as a known or anticipated carcinogen by NTP.

OSHA: No component of this product present at levels greater than or equal to 0.1% is identified as a carcinogen or potential carcinogen by OSHA.

Teratogenicity: No data available

Reproductive/fertility toxicity: Damage to fetus not classifiable

Specific target organ toxicity, single exposure (Methanol, CAS No. 67-56-1): Causes damage to organs

Specific target organ toxicity, repeated exposure: The substance or mixture is not classified as specific target organ toxicant, repeated exposure.

Additional information (Methanol, CAS No. 67-56-1): RTECS: PC1400000 Effects due to ingestion may include headache, dizziness, drowsiness, metabolic acidosis, coma, seizures. Methanol may be fatal or cause blindness if swallowed. Stomach - Irregularities - Based on Human Evidence

Section 12: Ecological Information

12.1 Toxicity: No data available

12.2 Persistence and degradability: Readily biodegradable

12.3 Bioaccumulative potential: No data available

12.4 Mobility in soil: No data available

12.5 Results of PBT and vPvB assessment: No data available

12.6 Other adverse effects: An environmental hazard cannot be excluded in the event of unprofessional handling or disposal.

Section 13: Disposal Considerations**13.1 Waste treatment methods**

Product: All waste must be handled and disposed according to local, state, and federal regulations. Avoid disposing large volumes in sewer.

Contaminated packaging: All waste must be handled and disposed according to local, state, and federal regulations.

Refer to sections 7 and 8 for safe handling guidance.

Section 14: Transport Information

DOT, Land Transport ADR/RID (cross-border), Maritime Transport IMDG, Air Transport ICAO-TI and IATA-DGR

UN Number: 3316

UN Proper shipping name: Chemical Kit, (contains Methanol)

Transport hazard class(es): 9

Packing group: III

Environmental hazard: See section 12

Bulk transport: Excepted/Limited quantity

Special considerations: See section 7 for handling

Section 15: Regulatory Information

EU Regulations, Hazard Symbol(s): Methanol: T (Toxic), F (Flammable)

Safety Phrases:

Methanol: S 7 / 16 / 36 / 37 / 45, Keep container tightly closed. Keep away from sources of ignition, no smoking. Wear suitable protective clothing and gloves. In case of accident or if you become ill, seek medical advice immediately (show product label).

SARA Title III, Section 313 Components: Methanol, CAS No. 67-56-1

SARA 311/312 Hazards: Methanol, CAS No. 67-56-1: Fire Hazard, Acute Health Hazard, Chronic Health Hazard

State Right-to-Know

Massachusetts: Methanol, CAS No. 67-56-1

Pennsylvania: Methanol, CAS No. 67-56-1

New Jersey: Methanol, CAS No. 67-56-1

California Prop. 65 Components: WARNING: This product contains a chemical known to the State of California to cause birth defects or other reproductive harm. Methanol, CAS No. 67-56-1

Section 16: Other information

This information is based on our present knowledge. While Abraxis , Inc. believes that the data contained herein are factual and the opinions expressed represent a best effort to present accurate information, the data are not to be taken as a warranty or representation for which Abraxis , Inc. assumes legal responsibility. The information shall not be taken as being all-inclusive and is to be used only as a guide. The data are offered solely for the user's consideration, investigation, and verification. These suggestions should not be confused with either state, municipal, or insurance requirements, or with national safety codes and constitute no warranty. Any use of these data and information must be determined by the user to be in accordance with applicable federal, state, and local regulations.

All materials and mixtures may present unknown hazards and should be used with caution. Since Abraxis , Inc. cannot control the methods, volumes, or conditions of use of this product, Abraxis , Inc. shall not be held liable for any damages or losses resulting from the handling or from contact with the product as described herein. An individual technically qualified to handle potentially hazardous chemicals must supervise the use of this material. This product is sold for research use only. It is not for any human or animal therapeutic or clinical diagnostic use.

Date this SDS was prepared: 5/20/2016

Version: 3

Changes from previous version: Abraxis, LLC changed to Abraxis, Inc.