

Gentamicin ELISA, Microtiter Plate

Enzyme-Linked Immunosorbent Assay for the Determination of Gentamicin in Contaminated Samples

Product No. 5111GEN1A

Importance of Gentamicin Determination

Antibiotic residues in foods pose a serious threat to public health. Gentamicin is an aminoglycoside antibiotic used for the treatment and prevention of infections caused by gram-negative and certain gram-positive bacteria including *Staphylococcus*. Treatment is administered intravenously, intramuscularly, or topically, as Gentamicin is not readily absorbed when administered orally. Gentamicin is not metabolized by the body and is released at various rates from different body tissues. Dosing must be carefully monitored, as Gentamicin has a narrow therapeutic range. Even at therapeutic levels, Gentamicin may be ototoxic, nephrotoxic, or cause nerve damage. Ototoxicity may cause damage to the inner ear, affecting balance, and can also result in hearing loss. Nephrotoxicity may cause cellular necrosis, which can result in acute renal failure.

The monitoring of water sources and food products, such as meat, milk and honey, for antibiotic residues is necessary to ascertain that these compounds are not misused and do not present a danger to human or animal health. In the European Union, the current maximum residue limit (MRL) for Gentamicin in milk is 100 µg/L and in meat is 50 µg/g.

The Abraxis Gentamicin ELISA allows the determination of 42 samples in duplicate determination. Only a few milliliters of sample are required. The test can be performed in less than 1 hour.

Performance Data

Test sensitivity:

The limit of detection for Gentamicin calculated as $X_n \pm 3SD$ (n=20) or as 90% B/Bound is equal to 0.19 ng/mL. The concentration of residue necessary to cause 50% inhibition (50% B/B₀) is approximately 1.0 ng/mL. Determinations closer to the middle of the calibration range of the test yield the most accurate results

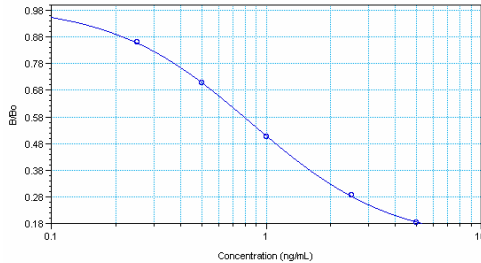

Test reproducibility: Coefficients of variation (CVs) for standards: <10%; CVs for samples: <15%.

Selectivity: This ELISA recognizes Gentamicin and related compounds with varying degrees:

Cross-reactivities: Gentamicin 100%

Samples: To eliminate matrix effects in milk and honey samples, sample dilution is required. See Preparation of Samples section. For additional extraction procedures for various matrices please contact Abraxis LLC.

General Limited Warranty: Abraxis LLC warrants the products manufactured by the Company against defects and workmanship when used in accordance with the applicable instructions for a period not to extend beyond the product's printed expiration date. **Abraxis makes no other warranty, expressed or implied. There is no warranty of merchantability or fitness for a particular purpose.**

For ordering or technical assistance contact:

India Contact:

Life Technologies (India) Pvt. Ltd.

306, Aggarwal City Mall, Road No. 44, Pitampura, Delhi – 110034, India

Mobile: +91-98105-21400, Tel: +91-11-42208000, 8111, 8222, Fax: +91-11-42208444

Email: customerservice@lifetechindia.com, www.atzlabs.com ; www.lifetechindia.com

1. General Description

The Gentamicin ELISA is an immunoassay for the detection of Gentamicin. This test is suitable for the quantitative and/or qualitative detection of Gentamicin in contaminated samples. Positive samples should be confirmed by HPLC, GC/MS, or other conventional methods.

2. Safety Instructions

The standard solutions in this test kit contain small amounts of Gentamicin in a basic solution. In addition, the substrate solution contains tetramethylbenzidine and the stop solution contains diluted sulfuric acid. Avoid contact of standard and stopping solutions with skin and mucous membranes. If these reagents come in contact with the skin, wash with water.

3. Storage and Stability

The Gentamicin ELISA Kit should be stored in the refrigerator (4–8°C). The solutions must be allowed to reach room temperature (20–25°C) before use. Reagents may be used until the expiration date on the box.

4. Test Principle

The test is a direct competitive ELISA based on the recognition of Gentamicin by specific antibodies. Gentamicin, when present in a sample, and a Gentamicin-enzyme conjugate compete for the binding sites of anti-Gentamicin antibodies which are immobilized on the wells of the microtiter plate. After a washing step and addition of the substrate solution, a color signal is produced. The intensity of the blue color is inversely proportional to the concentration of Gentamicin present in the sample. The color reaction is stopped after a specified time and the color is evaluated using an ELISA reader. The concentrations of the samples are determined by interpolation using the standard curve constructed with each run.

5. Limitations of the Gentamicin ELISA, Possible Test Interference

Numerous organic and inorganic compounds commonly found in samples have been tested and found not to interfere with this test. However, due to the high variability of compounds that might be found in samples, test interferences caused by matrix effects can not be completely excluded. Mistakes in handling the test can also cause errors. Possible sources for such errors can be:

Inadequate storage conditions of the test kit, incorrect pipetting sequence or inaccurate volumes of the reagents, too long or too short incubation times during the immune and/or substrate reaction, extreme temperatures during the test performance (lower than 10°C or higher than 30°C).

The Abraxis Gentamicin ELISA kit provides screening results. As with any analytical technique (GC, HPLC, etc.), positive samples requiring some action should be confirmed by an alternative method.

Working Instructions

A. Materials Provided

1. Microtiter plate coated anti-Gentamicin antibody, in a resealable foil pouch with desiccant.
2. Gentamicin Standards (6): 0, 0.25, 0.50, 1.0, 2.5 and 5.0 ng/mL.
3. Assay Buffer, 6 mL.
4. Sample Diluent (10X) Concentrate, 25 mL, must be diluted before use. Use to dilute samples.
5. Gentamicin-HRP Conjugate Solution, 12 mL.
6. Wash Solution (5X) Concentrate, 100 mL.
7. Color (Substrate) Solution (TMB), 12 mL.
8. Stop Solution, 12 mL.

B. Additional Materials (not included with the test kit)

1. Micro-pipettes with disposable plastic tips (10-200 and 200-1000 μL)
2. Multi-channel pipette (10-250 μL) or stepper pipette with plastic tips (10-250 μL)
3. Microtiter plate reader (wave length 450 nm)
4. Timer
5. Tape or Parafilm
6. Glass vials with Teflon-lined caps
7. Distilled or deionized water
8. Vortex mixer

C. Test Preparation

Micro-pipetting equipment and pipette tips for pipetting the standards and the samples are necessary. We recommend using a multi-channel pipette or a stepping pipette for adding the assay buffer, conjugate, substrate and stop solutions in order to equalize the incubations periods of the solutions on the entire microtiter plate. Please use only the reagents and standards from one package lot in one test, as they have been adjusted in combination.

1. Adjust the microtiter plate and the reagents to room temperature before use.
2. Remove the number of microtiter plate strips required from the foil bag. The remaining strips should be stored in the foil bag and zip-locked closed. Store the remaining kit in the refrigerator (4-8°C).
3. The standards, assay buffer, conjugate, substrate, and stop solutions are ready to use and do not require any further dilutions.
4. The standard solutions should be handled with care as they are strongly basic.
5. Dilute the sample diluent (10X) concentrate at a ratio of 1:10. If using the entire bottle (25 mL), add to 225 mL of deionized or distilled water.
6. Dilute the wash buffer (5X) concentrate at a ratio of 1:5. If using the entire bottle (100 mL), add to 400 mL of deionized or distilled water.
7. The stop solution should be handled with care as it contains diluted H_2SO_4 .

D. Preparation of Samples

Samples should be analyzed immediately after preparation to prevent adsorption/degradation of the analyte.

Milk

1. Add 900 μL of 1X diluted Sample Diluent to an appropriately labeled glass vial with a Teflon-lined cap.
2. Add 100 μL of milk sample. Vortex thoroughly.
3. Analyze as sample (Assay Procedure, step 1).

The Gentamicin concentration contained in milk samples is then determined by multiplying the ELISA result by the dilution factor of 10. Highly contaminated samples (those outside of the calibration range of the assay) must be diluted further in 1X Sample Diluent and re-analyzed.

Honey

1. Add 1 g of honey to a clean glass vial with a Teflon-lined cap.
2. Add 4 mL of distilled or deionized water. Vortex until honey is completely dissolved.
3. Analyze as sample (Assay Procedure, step 1).

The Gentamicin concentration contained in honey samples is then determined by multiplying the ELISA result by the dilution factor of 5. Highly contaminated samples (those outside of the calibration range of the assay) must be diluted further in 1X Sample Diluent and re-analyzed.

For additional extraction procedures for various matrices please contact Abraxis LLC.

E. Working Scheme

The microtiter plate consists of 12 strips of 8 wells, which can be used individually for the test. The standards must be run with each test. Never use the values of standards which have been determined in a test performed previously.

Std 0-Std 5: Standards

0: 0.25; 0.50; 1.0; 2.5; 5.0 ppb

Samp1, Samp2, etc.: Samples

	1	2	3	4	5	6	7	8	9	10	11	12
A	Std 0	Std 1	etc.									
B	Std 0	Std 1	etc.									
C	Std 1	Std 5										
D	Std 1	Std 5										
E	Std 2	Samp1										
F	Std 2	Samp1										
G	Std 3	Samp2										
H	Std 3	Samp2										

F. Assay Procedure

1. Add 25 μL of **assay buffer solution** to the individual wells successively using a multi-channel pipette or a stepping pipette.
2. Add 25 μL of the **standard solutions and samples or sample extracts** into the wells of the test strips according to the working scheme given. We recommend using duplicates or triplicates.
3. Add 100 μL of **enzyme conjugate solution** to the individual wells successively using a multi-channel pipette or a stepping pipette.
4. Cover the wells with parafilm or tape and mix the contents by moving the strip holder in a circular motion on the benchtop for 30 seconds. Be careful not to spill contents.
5. Incubate the strips for 30 minutes at room temperature.
6. After incubation, remove the covering and vigorously shake the contents of these wells into a sink. Wash the strips **three times** using the 1X washing buffer solution. Use 250 μL of washing buffer for each well and each washing step. Remaining buffer in the wells should be removed by patting the plate dry on a stack of paper towels.
7. Add 100 μL of **substrate (color) solution** to the wells. Cover the wells with parafilm or tape and mix the contents by moving the strip holder in a circular motion on the benchtop for 30 seconds. Incubate the strips for 15 minutes at room temperature. Protect the strips from direct sunlight.
8. Add 100 μL of **stop solution** to the wells in the same sequence as for the substrate solution.
9. Read the absorbance at 450 nm using a microplate ELISA photometer within 15 minutes after the addition of the stopping solution.

G. Evaluation

The evaluation of the ELISA can be performed using commercial ELISA evaluation programs (4-Parameter (preferred) or Logit/Log). For manual evaluation, calculate the mean absorbance value for each of the standards. Calculate the $\%B/B_0$ for each standard by dividing the mean absorbance value for each standard by the Zero Standard (Standard 0) mean absorbance. Construct a standard curve by plotting the $\%B/B_0$ for each standard on the vertical linear (y) axis versus the corresponding Gentamicin concentration on the horizontal logarithmic (x) axis on graph paper. $\%B/B_0$ for samples will then yield levels in ppb of Gentamicin by interpolation using the standard curve. Samples showing lower concentrations of Gentamicin compared to Standard 1 (0.25 ng/mL) should be reported as containing < 0.25 ng/mL. Samples showing a higher concentration than Standard 5 (5.0 ng/mL) must be diluted further to obtain accurate results.

Gentamicin Plate, Detailed ELISA Procedure

1. Addition of Assay Buffer

Add 25 μ l of Assay Buffer to the wells of the test strips successively using a multi-channel pipette or a stepping pipette according to the working scheme given. We recommend using duplicates or triplicates.

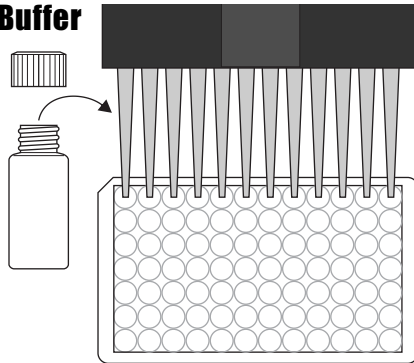

2. Addition of Standards, Samples

Add 25 μ l of the standard solutions and samples to the wells of the test strips according to the working scheme given.

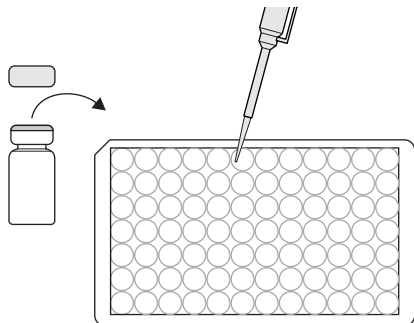

3. Addition of Conjugate Solution

Add 100 μ l of the enzyme conjugate to the individual wells successively using a multi-channel pipette or a stepping pipette. Cover the wells with parafilm or tape and mix the contents by moving the strip holder in a rapid circular motion on the benchtop. Be careful not to spill contents. Incubate the strips for 30 min at room temperature.

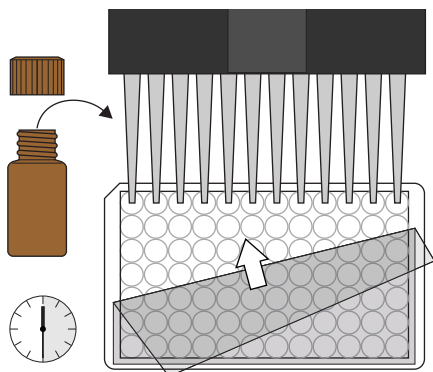

4. Washing of Plates

After incubation, remove the covering and vigorously shake the contents of the wells into a sink. Wash the strips three times with a multi-channel pipette or wash bottle using the diluted 1X washing buffer solution. Please use at least a volume of 250 μ l of washing buffer for each well and each washing step. Remaining buffer in the wells should be removed by patting the plate dry on a stack of paper towels.

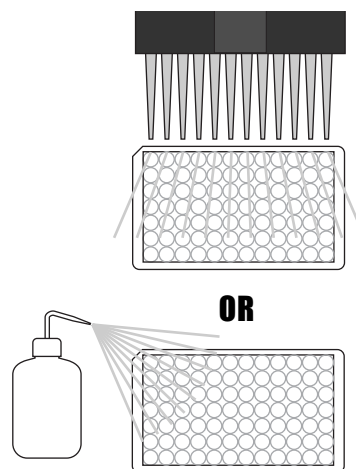

5. Addition of Substrate/Color Solution

Add 100 μ l of substrate/color solution to the individual wells successively using a multi-channel pipette or a stepping pipette. Cover the wells with parafilm or tape and mix the contents by moving the strip holder in a rapid circular motion on the benchtop. Be careful not to spill contents. Incubate the strips for 15 min at room temperature.

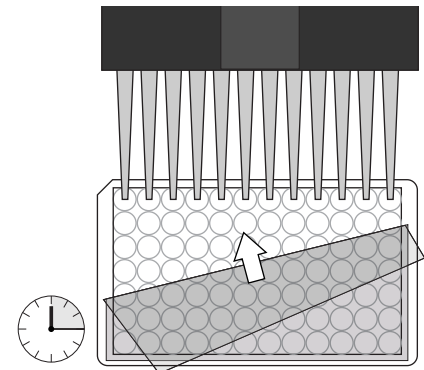

6. Addition of Stopping Solution

Add 100 μ l of stop solution to the wells in the same sequence as for the substrate solution using a multi-channel pipette or a stepping pipette.

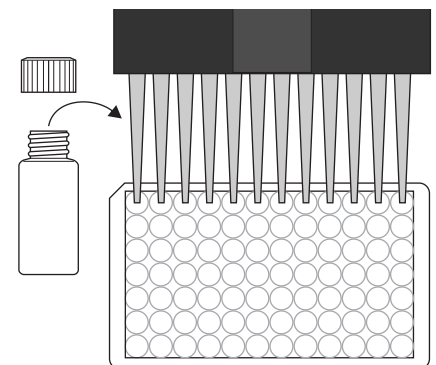

7. Measurement of Color

Read the absorbance at 450 nm using a microplate ELISA reader. Calculate results.

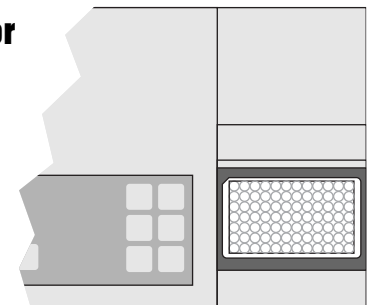

India Contact:

Life Technologies (India) Pvt. Ltd.

306, Aggarwal City Mall, Road No. 44, Pitampura, Delhi - 110034, India
Mobile: +91-98105-21400, Tel: +91-11-42208000, 8111, 8222, Fax: +91-11-42208444
Email: customerservice@lifetechindia.com, www.atzlabs.com; www.lifetechindia.com

Gentamicin Plate, Concise ELISA Procedure

1. Addition of Assay Buffer

Add 25 μ l of Assay Buffer.

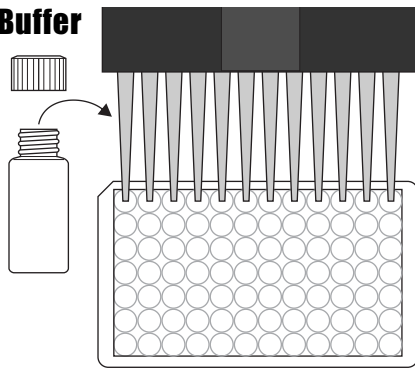

5. Addition of Substrate/Color Solution

Add 100 μ L of substrate/color solution. Incubate 15 minutes at room temperature and away from direct sunlight.

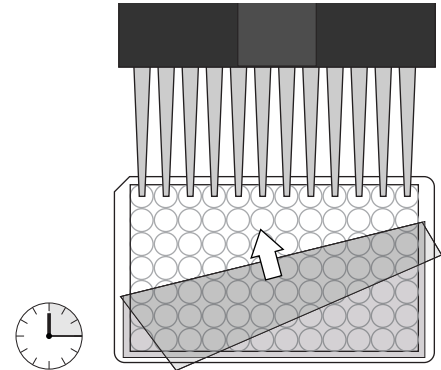

2. Addition of Standards, Samples

Add 25 μ l of the standard solutions and samples.

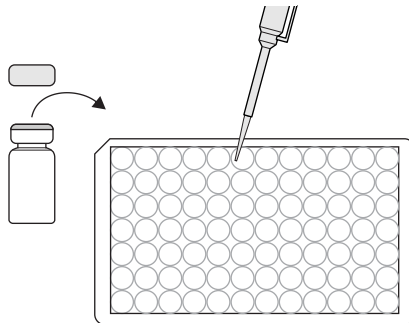

6. Addition of Stopping Solution

Add 100 μ L of stop solution.

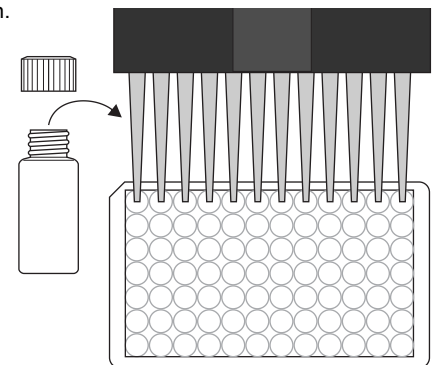

3. Addition of Conjugate Solution

Add 100 μ L of the enzyme conjugate. Cover and mix for 30 seconds by rotating on benchtop. Incubate for 30 min at room temperature.

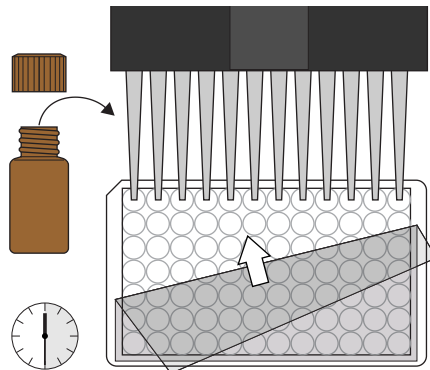

7. Measurement of Color

Measure color at 450 nm. Calculate results.

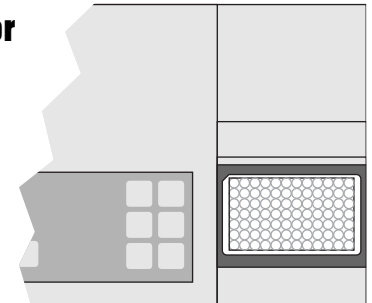

4. Washing of Plates

Wash the plates three times with 250 μ L of diluted 1X washing buffer.

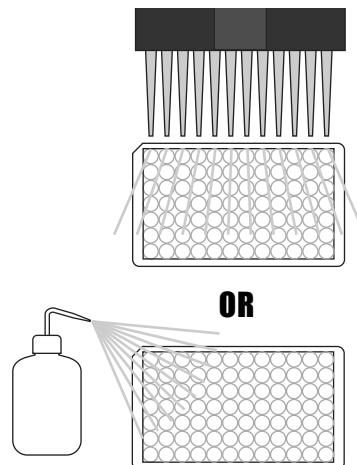

India Contact:

Life Technologies (India) Pvt. Ltd.

306, Aggarwal City Mall, Road No. 44, Pitampura, Delhi – 110034, India
Mobile: +91-98105-21400, Tel: +91-11-42208000, 8111, 8222, Fax: +91-11-42208444
Email: customerservice@lifetechindia.com, www.atzlabs.com; www.lifetechindia.com



Safety Data Sheet

Section 1: Product and Company Identification

1.1 Product Identifiers:

Product Name: Gentamicin ELISA Plate Kit

Product Code: 5111GEN1A

1.2 Identified Use: Determination of Gentamicin in samples. **Restrictions on Use:** For research use only.

1.3 Company: Abraxis, Inc., 124 Railroad Drive, Warminster, PA 18974 USA, info@abraxiskits.com +1(215) 357-3911, FAX +1(215) 357-5232

1.4 Emergency Telephone Number: +1(215) 357-3911

Section 2: Hazard(s) Identification

2.1 Classification of the mixture: Not a hazardous mixture.

2.2 GHS Label elements, including precautionary statements: Not applicable.

2.3 Hazards not otherwise classified (HNOC) or not covered by GHS: None known.

2.4 Unknown acute toxicity: None known.

Section 3: Composition / Information on Ingredients

3.2 Mixtures: *Contains no hazardous ingredients at levels requiring disclosure by the OSHA Hazard Communication Standard (29 CFR 1910.1200), however it contains minor amounts of materials considered hazardous. We recommend handling all substances with caution.*

Section 4: First Aid Measures

4.1 Description of first aid measures: Consult a physician. Show this safety data sheet to the doctor in attendance. Move out of dangerous area.

If inhaled: If breathed in, move person into fresh air. If not breathing, give artificial respiration. Consult a physician.

In case of skin contact: Wash off with soap and plenty of water. Consult a physician.

In case of eye contact: Rinse thoroughly with plenty of water for at least 15 minutes and consult a physician.

If swallowed: Never give anything by mouth to an unconscious person. Rinse mouth with water. Consult a physician.

4.2 Most important symptoms and effects, both acute and delayed: No data available

4.3 Indication of any immediate medical attention and special treatment needed: No data available. Treat symptomatically.

Section 5: Fire-fighting Measures

5.1 Suitable extinguishing media: Use an extinguishing agent suitable for the surrounding fire.

5.2 Special hazards arising from the substance or mixture: None known

5.3 Advice for firefighters: Wear self-contained breathing apparatus for fire-fighting if necessary.

5.4 Further information: No data available

Section 6: Accidental Release Measures

6.1 Personal precautions, protective equipment and emergency procedures: Use personal protective equipment (see section 8). Avoid dust formation. Avoid breathing vapors, mist, dust, or gas. Ensure adequate ventilation. Evacuate personnel to safe areas.

6.2 Environmental precautions: Prevent further leakage or spillage if safe to do so. Do not let product enter drains. Discharge into the environment must be avoided.

6.3 Methods and materials for containment and cleaning up: Solids (if applicable): Pick up and arrange disposal without creating dust. Sweep up and shovel. Liquids (if applicable): Absorb with liquid-binding material (sand, diatomite, acid binders, universal binders, sawdust). Keep in suitable, closed containers for disposal.

6.4 Reference to other sections: For information on safe handling see section 7.

For information on personal protection see section 8.

For information on disposal see section 13.

Section 7: Handling and Storage

7.1 Precautions for safe handling: See section 2. Avoid inhalation of vapors and contact with skin and eyes. Wear appropriate personal protective equipment. Do not eat, drink, or smoke in work area.

7.2 Precautions for safe storage: Keep container(s) tightly closed in a dry, well-ventilated place. Protect from physical damage. See label or product insert for appropriate storage temperature and additional specific information.

7.3 Specific end use(s): No data available

Section 8: Exposure Controls / Personal Protection

8.1 Control parameters: Not applicable.

8.2 Exposure controls:

Appropriate engineering controls: Provide adequate ventilation. Handle in accordance with good industrial hygiene and safety practice. Wash hands before breaks and at the end of workday. Keep away from food and beverages.

Personal protective equipment: The usual precautionary measures, including eye/face/skin protection, should be taken when handling any chemical. Avoid contact with eyes, skin, and clothing.

Eye protection: As with handling of any chemical, wear approved safety goggles.

Skin protection: Handle with gloves. No specific information regarding glove material or thickness is available, but gloves must be impermeable and resistant to the substance being handled. Gloves must be inspected prior to use. Use proper glove removal technique (without touching glove's outer surface) to avoid skin contact with this product. Dispose of contaminated gloves after use in accordance with applicable laws and good laboratory practices. Wash and dry hands.

Respiratory protection: As with any chemical, where excessive vapor, mist, or dust may result, use a chemical fume hood or approved respiratory protection equipment.

Body protection: Lightweight, protective clothing.

Section 9: Physical and Chemical Properties

9.1 Information on basic physical and chemical properties of the mixture

Appearance: Multiple

Odor: Characteristic

Odor Threshold: No data available

pH: Multiple

Melting point/freezing point: No data available

Initial boiling point and boiling range: No data available

Flash point: Not applicable

Evaporation rate: No data available

Flammability (solid, gas): No data available

Upper/lower flammability or explosive limits: No data available

Vapor pressure: No data available

Vapor density: No data available

Relative density: No data available

Water solubility: Various

Partition coefficient: n-octanol/water: No data available

Auto-ignition temperature: Not applicable

Decomposition temperature: No data available

Viscosity: No data available

Explosive properties: No data available

Oxidizing properties: No data available

9.2 Other information: No data available

Section 10: Stability and Reactivity

10.1 Reactivity: No data available

10.2 Chemical stability: Stable under recommended storage conditions.

10.3 Possibility of hazardous reactions: No data available

10.4 Conditions to avoid: No data available

10.5 Incompatible materials: No data available

10.6 Hazardous decomposition products: No data available. In the event of fire: see section 5.

Section 11: Toxicological Information

11.1 Information on toxicological effects

Acute toxicity: Not available. To the best of our knowledge, the chemical, physical, and toxicological properties of this product have not been thoroughly investigated.

Inhalation: No data available **Ingestion:** No data available

Skin contact: Irritant to skin and mucous membranes.

Eye contact: May cause eye irritation in susceptible persons.

Respiratory or skin sensitization: No data available

Aspiration hazard: No data available

Mutagenicity: No data available

Carcinogenicity

IARC: No component of this product present at levels greater than or equal to 0.1% is identified as probable, possible or confirmed human carcinogen by IARC.

ACGIH: No component of this product present at levels greater than or equal to 0.1% is identified as a carcinogen or potential carcinogen by ACGIH.

NTP: No component of this product present at levels greater than or equal to 0.1% is identified as a known or anticipated carcinogen by NTP.

OSHA: No component of this product present at levels greater than or equal to 0.1% is identified as a carcinogen or potential carcinogen by OSHA.

Teratogenicity: No data available

Reproductive/fertility toxicity: No data available

Specific target organ toxicity, single exposure: No data available

Specific target organ toxicity, repeated exposure: No data available

Section 12: Ecological Information

12.1 Toxicity: No data available

12.2 Persistence and degradability: No data available

12.3 Bioaccumulative potential: No data available

12.4 Mobility in soil: No data available

12.5 Results of PBT and vPvB assessment: No data available

12.6 Other adverse effects: An environmental hazard cannot be excluded in the event of unprofessional handling or disposal.

Section 13: Disposal Considerations

13.1 Waste treatment methods

Product: All waste must be handled and disposed according to local, state, and federal regulations. Avoid disposing large volumes in sewer.

Contaminated packaging: All waste must be handled and disposed according to local, state, and federal regulations.

Refer to sections 7 and 8 for safe handling guidance.

Section 14: Transport Information

UN Number: Not regulated

UN Proper shipping name: Not classified as dangerous in the meaning of transport regulations.

Transport hazard class(es): No data available

Packing group: No data available

Environmental hazard: No data available

Bulk transport: No data available

Special considerations: No data available

Section 15: Regulatory Information

To the best of our knowledge, this product contains no substances which, at their given concentrations, are considered hazardous by other regulatory agencies. Refer to section 3.

Section 16: Other information

This information is based on our present knowledge. While Abraxis, Inc. believes that the data contained herein are factual and the opinions expressed represent a best effort to present accurate information, the data are not to be taken as a warranty or representation for which Abraxis, Inc. assumes legal responsibility. The information shall not be taken as being all-inclusive and is to be used only as a guide. The data are offered solely for the user's consideration, investigation, and verification. These suggestions should not be confused with either state, municipal, or insurance requirements, or with national safety codes and constitute no warranty. Any use of these data and information must be determined by the user to be in accordance with applicable federal, state, and local regulations.

All materials and mixtures may present unknown hazards and should be used with caution. Since Abraxis, Inc. cannot control the methods, volumes, or conditions of use of this product, Abraxis, Inc. shall not be held liable for any damages or losses resulting from the handling or from contact with the product as described herein. An individual technically qualified to handle potentially hazardous chemicals must supervise the use of this material. This product is sold for research use only. It is not for any human or animal therapeutic or clinical diagnostic use.

Date this SDS was prepared: 5/20/2016

Version: 2

Changes from previous version: Abraxis, LLC changed to Abraxis, Inc.