

Importance of Microcystins/Nodularins Determination

Most of the world's population relies on surface freshwaters as its primary source for drinking water. The drinking water industry is constantly challenged with surface water contaminants that must be removed to protect human health. Toxic cyanobacterial blooms are an emerging issue worldwide due to increased source water nutrient pollution caused by eutrophication. Microcystins and Nodularins are cyclic toxin peptides. Microcystins (of which there are many structural variants, or congeners) have been found in fresh water throughout the world. To date, approximately 140 variants of Microcystin have been isolated. The most common variant is Microcystin-LR. Other common Microcystin variants include YR, RR, and LA. These toxins are produced by many types of cyanobacteria (blue-green algae), including *Microcystis*, *Anabaena*, *Oscillatoria*, *Nostoc*, *Anabaenopsis*, and terrestrial *Hapalosiphon*. Nodularins are produced by the genus *Nodularia* and are found in marine and brackish water.

Acute poisoning of humans and animals constitutes the most obvious problem from toxic cyanobacterial blooms, and in several cases has led to death. Human and animal exposure to these toxins occurs most frequently through ingestion of water, through drinking or during recreational activities in which water is swallowed. These toxins mediate their toxicity by inhibiting liver function and are potent inhibitors of the serine/threonine protein phosphatases, and therefore may act as tumor promoters.

To protect consumers from adverse health effects caused by these toxins, the World Health Organization (WHO) has proposed a provisional upper limit for Microcystin-LR of 1.0 ppb (µg/L) in drinking water. The U.S. Environmental Protection Agency (EPA) has also established guidelines for Microcystins in drinking water at 0.3 ppb (µg/L) for children below school age and 1.6 ppb (µg/L) for all other age groups.

Performance Data

Test sensitivity: The detection limit for this assay (90% B/B₀ calculated from the average of 46 standard curves), based on MC-LR, is 0.016 ppb (µg/L) (see representative curve, below left).

Test reproducibility: Coefficients of variation (CVs) for standards: <10%; for samples: <15%.

Selectivity*: The antibody exhibits very good cross-reactivity with all cyanobacterial cyclic peptide toxin congeners tested to date (see cross-reactivity illustration, below right).

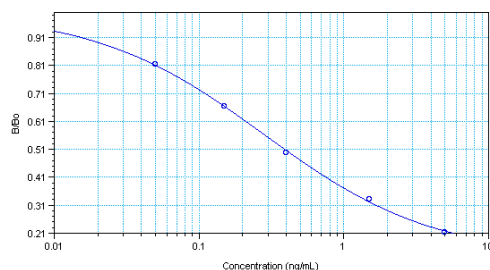

For demonstration purposes only. Not for use in sample interpretation.

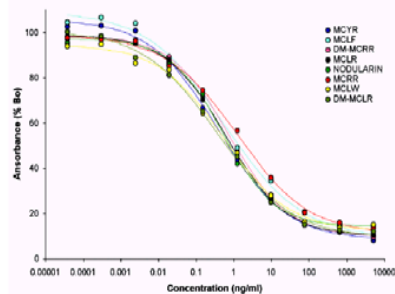

References

- (1) W. J. Fischer, I. Garthwaite, C.O. Miles, K.M. Ross, J.B. Aggen, A.R. Chamberlin, N.A. Towers, and D.R. Dietrich, Congener-Independent Immunoassay for Microcystins and Nodularins. *Environ. Sci. Technol.* 35, 2001, 4849-4858.
- (2) Worldwide Patenting PCT WO 01/18059 A2.
- (3) U.S. Patent Number 6,967,240.

General Limited Warranty/Disclaimer: Abraxis LLC warrants the products manufactured by the Company, against defects and workmanship when used in accordance with the applicable instructions for a period not to extend beyond the product's printed expiration date. Abraxis LLC makes no other warranty, expressed or implied. There is no warranty of merchantability or fitness for a particular purpose.

For ordering or technical assistance contact:

India Contact:

Life Technologies (India) Pvt. Ltd.

306, Aggarwal City Mall, Road No. 44, Pitampura, Delhi - 110034, India

Mobile: +91-98105-21400, Tel: +91-11-42208000, 8111, 8222, Fax: +91-11-42208444

Email: customerservice@lifetechindia.com, www.atzlabs.com; www.lifetechindia.com

Microcystins-ADDA SAES ELISA (Microtiter Plate)

Streptavidin Amplification Enhanced Sensitivity Enzyme-Linked Immunosorbent Assay for the Congener-Independent* Determination of Microcystins and Nodularins in Water Samples

Product No. 520011SAES

1. General Description

The Abraxis Microcystins-ADDA SAES ELISA is an enhanced sensitivity immunoassay for the quantitative and sensitive congener-independent* detection of Microcystins and Nodularins in water samples. This test is suitable for the quantitative and/or qualitative detection of Microcystins and Nodularins in water samples [please refer to the appropriate technical bulletins for sample collection, handling, and treatment of drinking (treated and untreated) and recreational water samples]. If necessary, positive samples can be confirmed by HPLC, protein phosphatase assay, or other conventional methods.

2. Safety Instructions

The standard solutions in the test kit contain small amounts of Microcystins. The substrate solution contains tetramethylbenzidine (TMB) and the stop solution contains diluted sulfuric acid. Avoid contact of the TMB and stopping solution with skin and mucous membranes. If these reagents come in contact with skin, wash with water.

3. Storage and Stability

The Microcystins-ADDA SAES ELISA kit should be stored in the refrigerator (4–8°C). The solutions must be allowed to reach room temperature (20–25°C) before use. Reagents may be used until the expiration date on the box. Consult state, local, and federal regulations for proper disposal of all reagents.

4. Microcystins-ADDA Antibody ELISA Test Principle

The test is an indirect competitive ELISA for the congener-independent detection of Microcystins and Nodularins. It is based on the recognition of Microcystins, Nodularins, and their congeners by specific biotinylated antibodies. Toxin, when present in a sample, and a Microcystins-protein analogue immobilized on the plate compete for the binding sites of the biotinylated anti-Microcystins/Nodularins antibodies in solution. The plate is then washed and a streptavidin-HRP is added. After a second washing step and addition of the substrate solution, a color signal is generated. The intensity of the blue color is inversely proportional to the concentration of Microcystins present in the sample. The color reaction is stopped after a specified time and the color is evaluated using an ELISA reader. The concentrations of the samples are determined by interpolation using the standard curve constructed with each run.

5. Limitations of the Microcystins-ADDA SAES ELISA, Possible Test Interference

Numerous organic and inorganic compounds commonly found in water samples have been tested and found not to interfere with this test. However, due to the high variability of compounds that may be found in water samples, test interferences caused by matrix effects cannot be completely excluded.

Samples containing methanol must be diluted to a concentration of < 1% methanol to avoid matrix effects.

No matrix effects have been observed with seawater samples (salinity up to 38 parts per thousand).

No matrix effects have been observed with samples which have been treated with sodium thiosulfate at concentrations ≤ 10 mg/mL or ascorbic acid at concentrations ≤ 1 mg/mL. *Note: Ascorbic acid used for dechlorination of treated drinking water samples may degrade Microcystins and may result in inaccurate (falsely low) results. See Sample Collection and Handling (section C) for information on the quenching of chlorinated water samples.*

Mistakes in handling the test can cause errors. Possible sources for such errors include: inadequate storage conditions of the test kit, incorrect pipetting sequence or inaccurate volumes of the reagents, too long or too short incubation times during the immune and/or substrate reaction, and extreme temperatures during the test performance (lower than 10°C or higher than 30°C).

As with any analytical technique (GC, HPLC, etc.), positive results requiring regulatory action should be confirmed by an alternative method.

A. Materials Provided

1. Microtiter plate (12 X 8 strips) coated with an analog of Microcystins conjugated to a protein
2. Standards (6): 0, 0.05, 0.15, 0.4, 1.5, 5.0 ppb
3. Control: 0.75 ± 0.185 ppb, prepared from a secondary source, for use as a Quality Control Standard (QCS)
4. Sample Diluent, for use as a Laboratory Reagent Blank (LRB) and for dilution of samples above the range of the standard curve
5. Microcystins-ADDA SAES Antibody Solution
6. Microcystins-ADDA SAES Conjugate Solution
7. Wash Solution (5X) Concentrate, must be diluted prior to use, see Test Preparation (Section E)
8. Substrate (Color) Solution (TMB)
9. Stop Solution

B. Additional Materials (not delivered with the test kit)

1. Micro-pipettes with disposable plastic tips (20-200 μ L)
2. Multi-channel pipette (50-300 μ L), stepper pipette (50-300 μ L), or electronic repeating pipette with disposable plastic tips
3. Deionized or distilled water
4. Container with 500 mL capacity (for 1X diluted wash solution, see Test Preparation, Section E)
5. Graduated cylinder
6. Paper towels or equivalent absorbent material
7. Timer
8. Tape or parafilm
9. Microtiter plate reader (wavelength 450 nm)
10. Microtiter plate washer (optional)

C. Sample Collection and Handling

Collect water samples in glass or PETG containers and test within 24 hours. Use of other types of plastic collection and/or storage containers may result in adsorptive loss of Microcystins, producing inaccurate (falsely low) results. Drinking water samples which contain chlorine or other oxidizers must be treated with sodium thiosulfate immediately after collection (refer to appropriate technical bulletin). If samples must be held for longer periods (up to 5 days), samples should be stored refrigerated. For storage periods greater than 5 days, samples should be stored frozen.

If total Microcystins concentration (free and cell bound) is required, an appropriate cell lysing procedure (freeze and thaw, QuikLyse™, etc.) must be performed prior to analysis. *Note: The use of sonication in cell lysing can negatively affect toxin concentrations, producing falsely low sample results. Please see the appropriate sample preparation technical bulletin for additional information on cell lysis.*

Samples may be filtered prior to analysis using glass fiber filters (Environmental Express 1.2 μ m syringe filters (Environmental Express part number SF012G) are recommended). If determining total Microcystins concentration, samples should be lysed prior to filtration to prevent the removal of cell-bound Microcystins, which would cause inaccurate (falsely low) results. *Note: The use of alternate filter types (non-glass fiber filters) may produce falsely low sample results, as Microcystins may bind to the filter material, removing it from the sample.*

D. Notes and Precautions

Micro-pipetting equipment and pipette tips for pipetting the standards and the samples are necessary.

The use of a multi-channel pipette, stepping pipette, or electronic repeating pipette is recommended for the addition of the antibody, enzyme conjugate, substrate, and stop solutions in order to equalize the incubation periods on the entire microtiter plate.

To avoid drift and obtain accurate results, the addition of the antibody, conjugate, color, and stop solutions should be performed in less than 2 minutes for each reagent. If additions to the entire microtiter plate cannot be completed in less than 2 minutes, run size should be decreased to the number of rows which can be pipetted in less than 2 minutes.

Please use only the reagents and standards from one kit lot in one test, as they have been adjusted in combination.

E. Test Preparation

1. Allow the reagents and samples to reach ambient temperature before use.
2. Remove the number of microtiter plate strips required from the resealable pouch. The remaining strips are stored in the pouch with the desiccant (tightly sealed).
3. The standards, control, sample diluent (LRB), antibody, enzyme conjugate, substrate, and stop solutions are ready to use and do not require any further dilutions.
4. Dilute the Wash Solution (5X) Concentrate at a ratio of 1:5 with deionized or distilled water. If using the entire bottle (100 mL), add to 400 mL of deionized or distilled water and mix thoroughly.

F. Working Scheme

The microtiter plate consists of 12 strips of 8 wells, which can be used individually for the test. The standards must be run with each test. Never use the values of standards which have been determined in a test performed previously.

	1	2	3	4	5	6	7	8	9	10	11	12
A	Std 0	Std 1	Sample1									
B	Std 0	Std 1	Sample1									
C	Std 1	Std 5	Sample2									
D	Std 1	Std 5	Sample2									
E	Std 2	Contr.	etc.									
F	Std 2	Contr.	etc.									
G	Std 3	LRB										
H	Std 3	LRB										

Std 0 - Std 5: Standards

Contr.: Control (QCS)

LRB: Laboratory Reagent Blank

Samp1, Samp2, etc: Samples

G. Assay Procedure

1. Add 50 μ L of the standard solutions, control, LRB, or samples into the wells of the test strips according to the working scheme given. Analysis in duplicate or triplicate is recommended.
2. Add 50 μ L of the antibody solution to the individual wells successively using a multi-channel pipette or a stepping pipette. Cover the wells with parafilm or tape and mix the contents by moving the strip holder in a circular motion on the benchtop for 30 seconds. Be careful not to spill the contents. Incubate the strips for 90 minutes at room temperature.
3. Remove the covering and decant the contents of the wells into a sink. Wash the strips three times using the 1X wash buffer solution. Please use at least a volume of 250 μ L of wash buffer for each well and each washing step. Remaining buffer in the wells should be removed by patting the plate dry on a stack of paper towels.
4. Add 100 μ L of the enzyme conjugate solution to the individual wells successively using a multi-channel pipette or a stepping pipette. Cover the wells with parafilm or tape and mix the contents by moving the strip holder in a circular motion on the benchtop for 30 seconds. Be careful not to spill the contents. Incubate the strips for 30 minutes at room temperature.
5. Remove the covering and decant the contents of the wells into a sink. Wash the strips three times using the 1X wash buffer solution. Please use at least a volume of 250 μ L of wash buffer for each well and each washing step. Remaining buffer in the wells should be removed by patting the plate dry on a stack of paper towels.
6. Add 100 μ L of substrate (color) solution to the individual wells successively using a multi-channel pipette or a stepping pipette. Cover the wells with parafilm or tape and mix the contents by moving the strip holder in a circular motion on the benchtop for 30 seconds. Be careful not to spill the contents. Incubate the strips for 20-30 minutes at room temperature. Protect the strips from sunlight.
7. Add 50 μ L of stop solution to the wells in the same sequence as for the substrate (color) solution using a multi-channel pipette or a stepping pipette.
8. Read the absorbance at 450 nm using a microplate ELISA photometer within 15 minutes after the addition of the stopping solution.

H. Evaluation

The evaluation of the ELISA can be performed using commercial ELISA evaluation programs such as 4-Parameter (preferred) or LogIt/Log. For a manual evaluation, calculate the mean absorbance value for each of the standards. Calculate the %B/B₀ for each standard by dividing the mean absorbance value for each standard by the Zero Standard (Standard 0) mean absorbance. Construct a standard curve by plotting the %B/B₀ for each standard on the vertical linear (y) axis versus the corresponding Microcystins concentration on the horizontal logarithmic (x) axis on graph paper. %B/B₀ for the control (QCS), LRB, and samples will then yield levels in ppb of Microcystins by interpolation using the standard curve. Results can also be determined using a spreadsheet macro available from Abraxis upon request.

The concentrations of the samples are determined using the standard curve run with each test. Samples showing a lower concentration of Microcystins than standard 1 (0.05 ppb) should be reported as containing < 0.05 ppb of Microcystins. Samples showing a higher concentration than standard 5 (5.0 ppb) must be diluted to obtain accurate results. The concentration of the positive control (QCS) provided should be 0.75 ± 0.185 ppb.

Semi-quantitative results can be derived by simple comparison of the sample absorbances to the absorbances of the calibrators. Samples with lower absorbances than a calibrator will have concentrations of Microcystins greater than that calibrator. Samples which have higher absorbances than a calibrator will have concentrations of Microcystins less than that calibrator.

Microcystins-ADDA SAES ELISA Kit, Detailed Procedure

1. Addition of Standards, Samples

Add 50 μ L of the standard solutions, control, or samples into the wells of the test strips according to the working scheme given. We recommend using duplicates or triplicates.

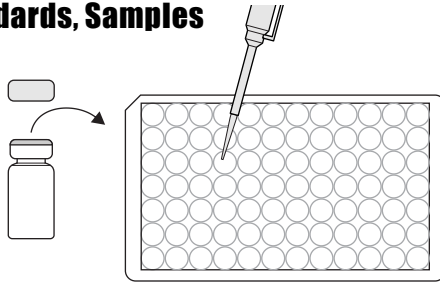

2. Addition of Antibody Solution

Add 50 μ L of the antibody solution to the individual wells successively using a multi-channel pipette or a stepping pipette. Cover the wells with parafilm or tape and mix the contents by moving the strip holder in a rapid circular motion on the benchtop for 30 seconds. Be careful not to spill contents. Incubate for 90 minutes at room temperature.

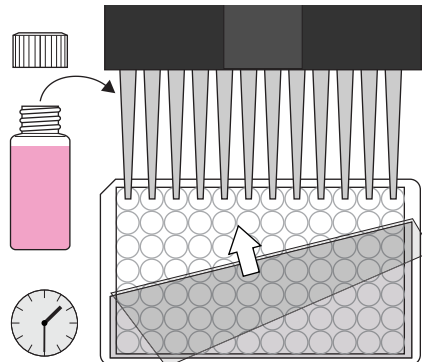

3. Washing of Plates

After incubation, remove the covering and vigorously shake the contents of the wells into a sink. Wash the strips three times with a multi-channel pipette using the 1X washing buffer solution. Please use at least a volume of 250 μ L of washing buffer for each well and each washing step. Remaining buffer in the wells should be removed by patting the plate dry on a stack of paper towels.

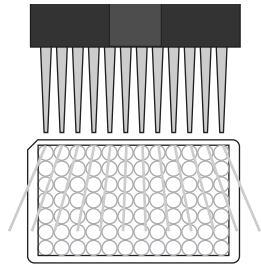

4. Addition of Enzyme Conjugate

Add 100 μ L of enzyme conjugate solution to the individual wells successively using a multi-channel pipette or a stepping pipette. Cover the wells with parafilm or tape and mix the contents by moving the strip holder in a rapid circular motion on the benchtop. Incubate for 30 minutes at room temperature.

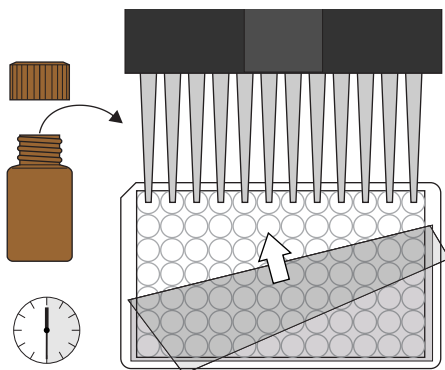

5. Washing of Plates

After incubation, remove the covering and vigorously shake the contents of the wells into a sink. Wash the strips three times with a multi-channel pipette using the 1X washing buffer solution. Please use at least a volume of 250 μ L of washing buffer for each well and each washing step. Remaining buffer in the wells should be removed by patting the plate dry on a stack of paper towels.

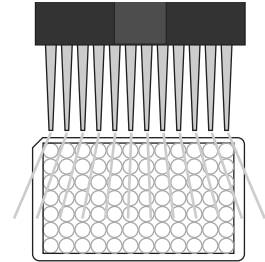

6. Addition of Substrate/Color Solution

Add 100 μ L of substrate/color solution to the wells using a multi-channel pipette or a stepping pipette. The strips are incubated for 20-30 minutes at room temperature. Protect the strips from direct sunlight.

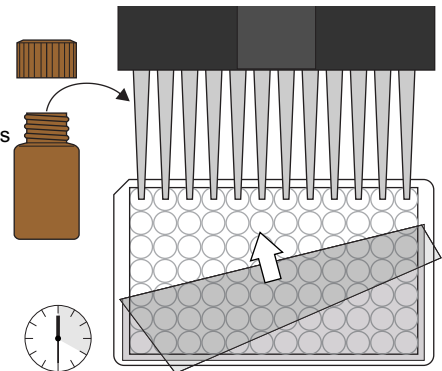

7. Addition of Stopping Solution

Add 50 μ L of stop solution to the wells in the same sequence as for the substrate solution using a multi-channel pipette or a stepping pipette.

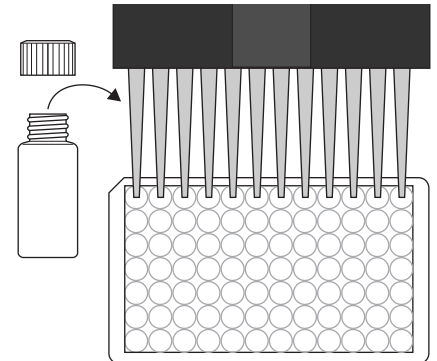

8. Measurement of Color

Read the absorbance at 450 nm using a microplate ELISA reader. Calculate results.

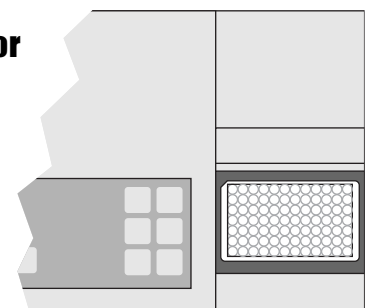

India Contact:

Life Technologies (India) Pvt. Ltd.

306, Aggarwal City Mall, Road No. 44, Pitampura, Delhi – 110034, India

Mobile: +91-98105-21400, Tel: +91-11-42208000, 8111, 8222, Fax: +91-11-42208444

Email: customerservice@lifetechindia.com, www.atzlabs.com; www.lifetechindia.com

Microcystins-ADDA SAES ELISA Kit, Concise Procedure

1. Addition of Standards, Samples

Add 50 μ L of the standard solutions, control, or samples.

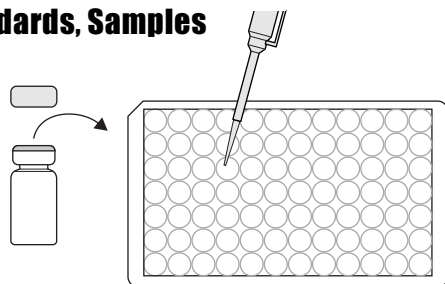

2. Addition of Antibody Solution

Add 50 μ L of the antibody solution. Cover and mix for 30 seconds by rotating on benchtop. Incubate for 90 minutes at room temperature.

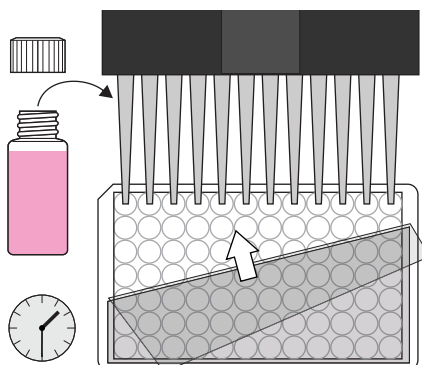

3. Washing of Plates

Wash plates three times with 250 μ L of 1X washing buffer.

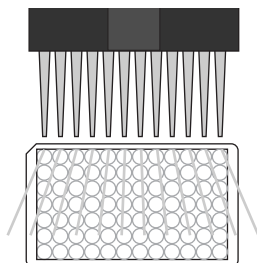

4. Addition of Enzyme Conjugate

Add 100 μ L of enzyme conjugate. Incubate for 30 minutes at room temperature.

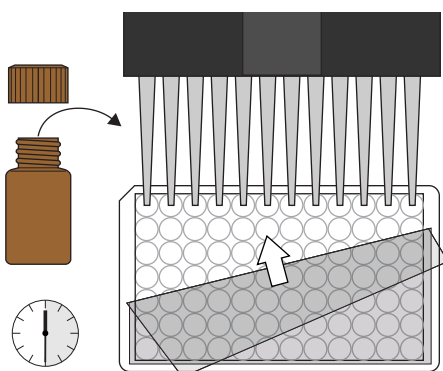

5. Washing of Plates

Wash plates three times with 250 μ L of 1X washing buffer.

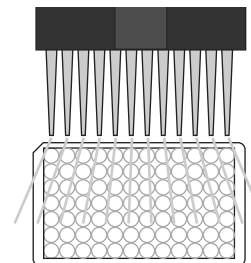

6. Addition of Substrate/Color Solution

Add 100 μ L of substrate/color solution. Incubate for 20-30 minutes at room temperature and away from direct sunlight.

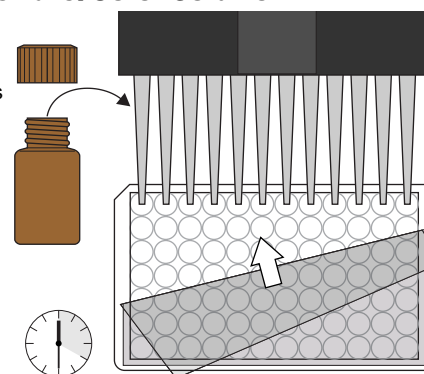

7. Addition of Stopping Solution

Add 50 μ L of stop solution.

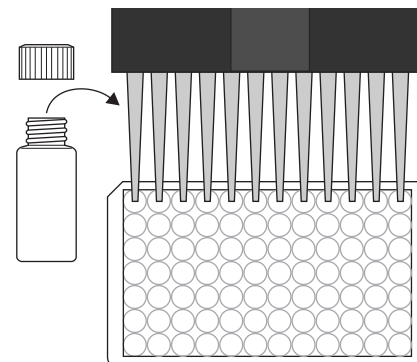

8. Measurement of Color

Measure color at 450 nm. Calculate results.

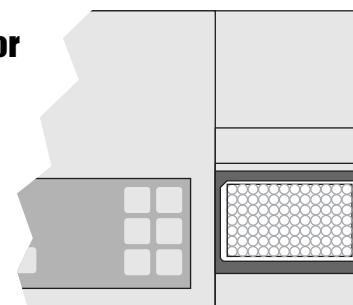

India Contact:

Life Technologies (India) Pvt. Ltd.

306, Aggarwal City Mall, Road No. 44, Pitampura, Delhi - 110034, India
Mobile: +91-98105-21400, Tel: +91-11-42208000, 8111, 8222, Fax: +91-11-42208444
Email: customerservice@lifetechindia.com, www.atzlabs.com; www.lifetechindia.com



Safety Data Sheet

Section 1: Product and Company Identification

1.1 Product Identifiers:

Product Name: Microcystins/Nodularins ADDA ELISA, Microcystins/Nodularins ADDA ES ELISA, Microcystins/Nodularins ADDA SAES ELISA, Microcystins/Nodularins ADDA OH ELISA, Microcystins/Nodularins DM ELISA, Microcystins/Nodularins (ADDA) cELISA Plate Kits

Product Code: 520011, 520011ES, 520011SAES, 520011OH, 522015, 520013

1.2 Identified Use: Determination of Microcystins/Nodularins in samples. **Restrictions on Use:** For research use only.

1.3 Company: Abraxis, Inc., 124 Railroad Drive, Warminster, PA 18974 USA, info@abraxiskits.com +1(215) 357-3911, FAX +1(215) 357-5232

1.4 Emergency Telephone Number: +1(215) 357-3911

Section 2: Hazard(s) Identification

2.1 Classification of the mixture: Not a hazardous mixture.

2.2 GHS Label elements, including precautionary statements: Not applicable.

2.3 Hazards not otherwise classified (HNOC) or not covered by GHS: None known.

2.4 Unknown acute toxicity: None known.

Section 3: Composition / Information on Ingredients

3.2 Mixtures: *Contains no hazardous ingredients at levels requiring disclosure by the OSHA Hazard Communication Standard (29 CFR 1910.1200)*, however it contains minor amounts of materials considered hazardous. We recommend handling all substances with caution.

Section 4: First Aid Measures

4.1 Description of first aid measures: Consult a physician. Show this safety data sheet to the doctor in attendance. Move out of dangerous area.

If inhaled: If breathed in, move person into fresh air. If not breathing, give artificial respiration. Consult a physician.

In case of skin contact: Wash off with soap and plenty of water. Consult a physician.

In case of eye contact: Rinse thoroughly with plenty of water for at least 15 minutes and consult a physician.

If swallowed: Never give anything by mouth to an unconscious person. Rinse mouth with water. Consult a physician.

4.2 Most important symptoms and effects, both acute and delayed: No data available

4.3 Indication of any immediate medical attention and special treatment needed: No data available. Treat symptomatically.

Section 5: Fire-fighting Measures

5.1 Suitable extinguishing media: Use an extinguishing agent suitable for the surrounding fire.

5.2 Special hazards arising from the substance or mixture: None known

5.3 Advice for firefighters: Wear self-contained breathing apparatus for fire-fighting if necessary.

5.4 Further information: No data available

Section 6: Accidental Release Measures

6.1 Personal precautions, protective equipment and emergency procedures: Use personal protective equipment (see section 8). Avoid dust formation. Avoid breathing vapors, mist, dust, or gas. Ensure adequate ventilation. Evacuate personnel to safe areas.

6.2 Environmental precautions: Prevent further leakage or spillage if safe to do so. Do not let product enter drains. Discharge into the environment must be avoided.

6.3 Methods and materials for containment and cleaning up: Solids (if applicable): Pick up and arrange disposal without creating dust. Sweep up and shovel. Liquids (if applicable): Absorb with liquid-binding material (sand, diatomite, acid binders, universal binders, sawdust). Keep in suitable, closed containers for disposal.

6.4 Reference to other sections: For information on safe handling see section 7.

For information on personal protection see section 8.

For information on disposal see section 13.

Section 7: Handling and Storage

7.1 Precautions for safe handling: See section 2. Avoid inhalation of vapors and contact with skin and eyes. Wear appropriate personal protective equipment. Do not eat, drink, or smoke in work area.

7.2 Precautions for safe storage: Keep container(s) tightly closed in a dry, well-ventilated place. Protect from physical damage. See label or product insert for appropriate storage temperature and additional specific information.

7.3 Specific end use(s): No data available

Section 8: Exposure Controls / Personal Protection

8.1 Control parameters: Not applicable.

8.2 Exposure controls:

Appropriate engineering controls: Provide adequate ventilation. Handle in accordance with good industrial hygiene and safety practice. Wash hands before breaks and at the end of workday. Keep away from food and beverages.

Personal protective equipment: The usual precautionary measures, including eye/face/skin protection, should be taken when handling any chemical. Avoid contact with eyes, skin, and clothing.

Eye protection: As with handling of any chemical, wear approved safety goggles.

Skin protection: Handle with gloves. No specific information regarding glove material or thickness is available, but gloves must be impermeable and resistant to the substance being handled. Gloves must be inspected prior to use. Use proper glove removal technique (without touching glove's outer surface) to avoid skin contact with this product. Dispose of contaminated gloves after use in accordance with applicable laws and good laboratory practices. Wash and dry hands.

Respiratory protection: As with any chemical, where excessive vapor, mist, or dust may result, use a chemical fume hood or approved respiratory protection equipment.

Body protection: Lightweight, protective clothing.

Section 9: Physical and Chemical Properties

9.1 Information on basic physical and chemical properties

Appearance: Multiple

Odor: Characteristic

Odor Threshold: No data available

pH: Multiple

Melting point/freezing point: No data available

Initial boiling point and boiling range: No data available

Flash point: Not applicable

Evaporation rate: No data available

Flammability (solid, gas): No data available

Upper/lower flammability or explosive limits: No data available

Vapor pressure: No data available

Vapor density: No data available

Relative density: No data available

Water solubility: Various

Partition coefficient: n-octanol/water: No data available

Auto-ignition temperature: Not applicable

Decomposition temperature: No data available

Viscosity: No data available

Explosive properties: No data available

Oxidizing properties: No data available

9.2 Other information: No data available

Section 10: Stability and Reactivity

10.1 Reactivity: No data available

10.2 Chemical stability: Stable under recommended storage conditions.

10.3 Possibility of hazardous reactions: No data available

10.4 Conditions to avoid: No data available

10.5 Incompatible materials: No data available

10.6 Hazardous decomposition products: No data available. In the event of fire: see section 5.

Section 11: Toxicological Information

11.1 Information on toxicological effects

Acute toxicity: Not available. To the best of our knowledge, the chemical, physical, and toxicological properties of this product have not been thoroughly investigated.

Inhalation: No data available **Ingestion:** No data available

Skin contact: Irritant to skin and mucous membranes.

Eye contact: May cause eye irritation in susceptible persons.

Respiratory or skin sensitization: No data available **Aspiration hazard:** No data available

Mutagenicity: No data available

Carcinogenicity

IARC: No component of this product present at levels greater than or equal to 0.1% is identified as probable, possible or confirmed human carcinogen by IARC.

ACGIH: No component of this product present at levels greater than or equal to 0.1% is identified as a carcinogen or potential carcinogen by ACGIH.

NTP: No component of this product present at levels greater than or equal to 0.1% is identified as a known or anticipated carcinogen by NTP.

OSHA: No component of this product present at levels greater than or equal to 0.1% is identified as a carcinogen or potential carcinogen by OSHA.

Teratogenicity: No data available **Reproductive/fertility toxicity:** No data available

Specific target organ toxicity, single exposure: No data available

Specific target organ toxicity, repeated exposure: No data available

Section 12: Ecological Information

12.1 Toxicity: No data available

12.2 Persistence and degradability: No data available

12.3 Bioaccumulative potential: No data available

12.4 Mobility in soil: No data available

12.5 Results of PBT and vPvB assessment: No data available

12.6 Other adverse effects: An environmental hazard cannot be excluded in the event of unprofessional handling or disposal.

Section 13: Disposal Considerations

13.1 Waste treatment methods

Product: All waste must be handled and disposed according to local, state, and federal regulations. Avoid disposing large volumes in sewer.

Contaminated packaging: All waste must be handled and disposed according to local, state, and federal regulations.

Refer to sections 7 and 8 for safe handling guidance.

Section 14: Transport Information

UN Number: Not regulated **UN Proper shipping name:** Not classified as dangerous in the meaning of transport regulations.

Transport hazard class(es): No data available **Packing group:** No data available **Environmental hazard:** No data available

Bulk transport: No data available **Special considerations:** No data available

Section 15: Regulatory Information

To the best of our knowledge, this product contains no substances which, at their given concentrations, are considered hazardous by other regulatory agencies. Refer to section 3.

Section 16: Other information

This information is based on our present knowledge. While Abraxis , Inc. believes that the data contained herein are factual and the opinions expressed represent a best effort to present accurate information, the data are not to be taken as a warranty or representation for which Abraxis , Inc. assumes legal responsibility. The information shall not be taken as being all-inclusive and is to be used only as a guide. The data are offered solely for the user's consideration, investigation, and verification. These suggestions should not be confused with either state, municipal, or insurance requirements, or with national safety codes and constitute no warranty. Any use of these data and information must be determined by the user to be in accordance with applicable federal, state, and local regulations.

All materials and mixtures may present unknown hazards and should be used with caution. Since Abraxis , Inc. cannot control the methods, volumes, or conditions of use of this product, Abraxis , Inc. shall not be held liable for any damages or losses resulting from the handling or from contact with the product as described herein. An individual technically qualified to handle potentially hazardous chemicals must supervise the use of this material. This product is sold for research use only. It is not for any human or animal therapeutic or clinical diagnostic use.

Date this SDS was prepared: 5/20/2016

Version: 3

Changes from previous version: Abraxis, LLC changed to Abraxis, Inc.