

Importance of Brevetoxin Determination

Neurotoxic shellfish poisoning (NSP) is caused by polyether toxins known as Brevetoxins. Brevetoxins (PbTx) are produced by the dinoflagellate *Karenia brevis*, which causes harmful algal blooms (HABs) known as red tides. The Brevetoxins are toxic to fish, marine mammals, birds and humans, but not to shellfish. Contamination of shellfish with Brevetoxin has been associated with the presence of harmful algal blooms in various parts of the world.

Mortality events attributed to HABs have been documented for fish, manatee, dolphins, and seabirds. In man, NSP causes dose-dependent symptoms of diarrhea, nausea, and vomiting, chills, sweats, reversal of temperature, hypotension, arrhythmias, numbness, tingling, bronchoconstriction, paralysis, seizures, and coma.

The Brevetoxin ELISA allows the determination of 40 samples in duplicate determination. Only a few milliliters of sample are required. The test can be performed in less than 2 hours.

Performance Data

Test sensitivity:

The limit of detection for Brevetoxin is calculated as: $Xn \pm 3SD$ ($n=20$) and is equal to 0.05 ng/ml in water and 22.5 ng/gm in diluted shellfish (when using a dilution factor of 450). The concentration of residue necessary to cause 50% inhibition (50% B/B₀) is approximately 0.16 ng/mL. Determinations closer to the middle of the calibration range of the test yield the most accurate results.

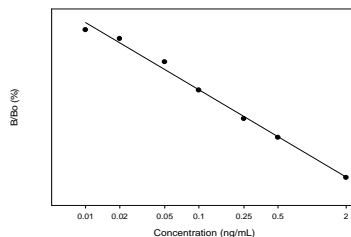

Test reproducibility: Coefficients of variation (CVs) for standards: <10%, CVs for samples: <15%.

Selectivity: This ELISA recognizes Brevetoxin and other NSP toxins to varying degrees:

Cross-reactivities:		
PbTx-3		100%
Deoxy PbTx-2		133%
PbTx-5		127%
PbTx-2		102%
PbTx-9		83%
PbTx-6		13%
PbTx-1		5%

No cross-reactivity was shown with any of the following common PSP shellfish toxins: saxitoxin, neosaxitoxin, dc-STX, gonyautoxins-1/4, gonyautoxins-2/3, B-2; B-1; C-1/2 and domoic acid.

Samples: Salt Water and shellfish samples (after recommended dilution) were tested for matrix effects in the ELISA. No matrix effects were determined.

General Limited Warranty: Abraxis LLC warrants the products manufactured by the Company, against defects and workmanship when used in accordance with the applicable instructions for a period not to extend beyond the product's printed expiration date. **Abraxis makes no other warranty, expressed or implied. There is no warranty of merchantability or fitness for a particular purpose**

For ordering or technical assistance contact:

India Contact:

Life Technologies (India) Pvt. Ltd.

306, Aggarwal City Mall, Road No. 44, Pitampura, Delhi – 110034, India

Mobile: +91-98105-21400, Tel: +91-11-42208000, 8111, 8222, Fax: +91-11-42208444

Email: customerservice@lifetechindia.com, www.atzlabs.com; www.lifetechindia.com

Brevetoxin (NSP) ELISA, Microtiter Plate

Enzyme-Linked Immunosorbent Assay for the Determination of Brevetoxin (NSP) in Water and Contaminated Samples

Product No. 520026

1. General Description

The Brevetoxin ELISA is an immunoassay for the quantitative and sensitive detection of Brevetoxin. Brevetoxin is one of the toxins associated with neurotoxic shellfish poisoning (NSP). This test is suitable for the quantitative and/or qualitative detection of Brevetoxin in water samples as well as shellfish samples. For shellfish samples a sample preparation is required. If necessary, positive samples can be confirmed by HPLC, GC/MS, or other conventional methods.

2. Safety Instructions

The standard solutions in this test kit contain small amounts of Brevetoxin (PbTx-3). In addition, the substrate solution contains tetramethylbenzidine and the stop solution contains diluted sulfuric acid. Avoid contact of stopping solution with skin and mucous membranes. If these reagents come in contact with the skin, wash with water.

3. Storage and Stability

The Brevetoxin ELISA should be stored in the refrigerator (4–8°C). The solutions must be allowed to reach room temperature (20-25°C) before use. Reagents may be used until the expiration date on the box.

4. Test Principle

The test is a direct competitive ELISA based on the recognition of Brevetoxin by specific antibodies. Brevetoxin, when present in a sample, and a Brevetoxin enzyme-conjugate compete for the binding sites of sheep anti-brevetoxin antibodies that have been immobilized in the wells of a microtiter plate. After a washing step and addition of the substrate solution, a color signal is produced. The intensity of the blue color is inversely proportional to the concentration of Brevetoxin present in the sample. The color reaction is stopped after a specified time and the color is evaluated using an ELISA reader. The concentrations of the samples are determined by interpolation using the standard curve constructed with each run.

5. Limitations of the Brevetoxin ELISA, Possible Test Interference

Numerous organic and inorganic compounds commonly found in samples have been tested and found not to interfere with this test. However, due to the high variability of compounds that might be found in samples, test interferences caused by matrix effects can not be completely excluded. Mistakes in handling the test can also cause errors. Possible sources for such errors can be:

Inadequate storage conditions of the test kit, incorrect pipetting sequence or inaccurate volumes of the reagents, too long or too short incubation times during the immune and/or substrate reaction, extreme temperatures during the test performance (lower than 10°C or higher than 30°C).

The Abraxis Brevetoxin ELISA kit provides screening results. As with any analytical technique (GC, HPLC, etc.) positive samples requiring some action should be confirmed by an alternative method.

Working Instructions

A. Materials Provided

1. Microtiter plate coated with sheep anti-Brevetoxin
2. Standards PbTx-3 (8): 0, 0.010, 0.025, 0.05, 0.1, 0.25, 0.5, 2.0 ng/mL
3. Brevetoxin-HRP Conjugate, 6 mL
4. Sample Diluent (1X), 2 X 30 mL. Use to dilute samples
5. Wash Solution (5X) Concentrate, 100 mL
6. Color Solution (TMB), 12 mL
7. Stop Solution, 2 X 6 mL
8. Sea Water Pre-treatment Solution, 25 mL

B. Test Preparation

Micro-pipetting equipment and pipette tips for pipetting the standards and the samples are necessary. We recommend using a multi-channel pipette or a stepping pipette for adding the conjugate, the substrate solution and the stop solution in order to equalize the incubations periods of the standard solutions and the samples on the entire microtiter plate. Please use only the reagents and standards from one package lot in one test, as they have been adjusted in combination.

1. Adjust the microtiter plate and the reagents to room temperature before use.
2. Remove the number of microtiter plate strips required from the foil bag. The remaining strips are stored in the foil bag and zip-locked closed. Store the remaining kit in the refrigerator (4-8°C).
3. The standard solutions, enzyme conjugate, substrate and stop solution are ready to use and do not require any further dilutions.
4. Dilute the Wash Buffer at a ratio of 1:5. If using the entire bottle (100 mL), add to 400 mL of deionized or distilled water.
5. The stop solution should be handled with care as it contains diluted H₂SO₄.

C. Assay Procedure

1. Add 50 µL of the **standard solutions or the samples (water) or sample extracts (shellfish)** into the wells of the test strips according to the working scheme given. We recommend using duplicates or triplicates.
2. Add 50 µL of **enzyme conjugate** solution to the individual wells successively using a multi-channel pipette or a stepping pipette. Cover the wells with parafilm or tape and mix the contents by moving the strip holder in a rapid circular motion on the benchtop for about 30 seconds. Be careful not to spill contents. Incubate for 60 minutes.
3. After incubation, remove the covering and vigorously shake the contents of these wells into a sink. Wash the strips three times using the 1X washing buffer solution. Use at least a volume of 250 µL of washing buffer for each well and each washing step. Remaining buffer in the wells should be removed by patting the plate dry on a stack of paper towels.
4. Add 100 µL of **substrate solution** to the wells. The strips are incubated for 30 min at room temperature. Protect the strips from direct sunlight.
5. Add 100 µL of **stop solution** to the wells in the same sequence as for the substrate solution.
6. Read the absorbance at 450 nm using a microplate ELISA photometer within 15 minutes after the addition of the stopping solution.

D. Evaluation

The evaluation of the ELISA can be performed using commercial ELISA evaluation programs (4-Parameter (preferred) or Logit/Log). For manual evaluation, calculate the mean absorbance value for each of the standards. Calculate the %B/B₀ for each standard by dividing the mean absorbance value for each standard by the Zero Standard (Standard 0) mean absorbance. Construct a standard curve by plotting the %B/B₀ for each standard on the vertical linear (y) axis versus the corresponding Brevetoxin concentration on the

horizontal logarithmic (x) axis on graph paper. %B/B₀ for samples will then yield levels in ppb of Brevetoxin by interpolation using the standard curve. Samples showing lower concentrations of Brevetoxin compared to standard 1 (0.01 ng/mL) are considered as negative. Samples showing a higher concentration than standard 7 (2.0 ng/mL) must be diluted further to obtain more accurate results.

E. Additional Materials (not delivered with the test kit)

1. Micro-pipettes with disposable plastic tips (10-200, and 200-1000 µL)
2. Multi-channel pipette (10-250 µL) or stepper pipette with plastic tips (10-250 µL)
3. Microtiter plate washer (optional)
4. Microtiter plate reader (wave length 450 nm)
5. Shaker for microtiter plates (optional)

F. Working Scheme

The microtiter plate consists of 12 strips of 8 wells, which can be used individually for the test. The standards must be run with each test. Never use the values of standards which have been determined in a test performed previously.

Std 0-Std 7: Standards
0; 0.010; 0.025; 0.05; 0.1; 0.25
0.5; 2.0 (ng/mL) or ppb

Sam1, Sam2, etc.: Samples

	1	2	3	4	5	6	7	8	9	10	11	12
A	Std 0	Std 4	Sam 1	etc.								
B	Std 0	Std 4	Sam 1									
C	Std 1	Std 5	Sam 7									
D	Std 1	Std 5	Sam 7									
E	Std 2	Std 6	etc.									
F	Std 2	Std 6	etc.									
G	Std 3	Std 7										
H	Std 3	Std 7										

G. Preparation of Samples

I. Mussels

1. Mussels are removed from their shells, washed with deionized water, thoroughly dried and homogenized (Waring blender, Polytron or equivalent).
2. A 1.0 gm portion of the homogenized mussels is then placed in a 40 mL glass vial.
3. Add 9.0 mL of a methanol/deionized water solution (9:1 v/v).
4. Vial is capped and hand shaken vigorously for 2 minutes.
5. Centrifuge mixture for 10 minutes at 3000 g. Collect the supernatant.
6. Remove 20 µL of collected extract and dilute to 1.0 mL with Sample Diluent (equals a 1:50 dilution).
7. Analyze diluted extracts as samples (Assay Procedure step 1).

The Brevetoxin concentration contained in the samples is determined by multiplying the concentration of the diluted extract by a factor of 450. Highly contaminated samples outside the range of the curve should be diluted further and re-analyzed.

II. Sea Water

1. Collect 2 mL of sea water sample in a glass container.
2. To prevent loss of Brevetoxin to the glass surface, immediately add 0.5 mL of Sea Water Pretreatment Solution, mix by hand.
3. Analyze preserved sample as samples (Assay Procedure step 1)

The Brevetoxin concentration contained in the sea water sample is determined by multiplying the concentration of the diluted sample by a factor of 1.25. Highly contaminated samples outside the range of the curve should be diluted in Sample Diluent (PN 205226), and re-analyzed. Additional Sample Diluent or Sea Water-Pretreatment Solution (PN 205227) can be purchased from Abraxis.

Brevetoxin (NSP) Plate, Detailed ELISA Procedure

1. Addition of Standards, Samples

Add 50 uL of the standard solutions or samples into the wells of the test strips according to the working scheme given. We recommend using duplicates or triplicates.

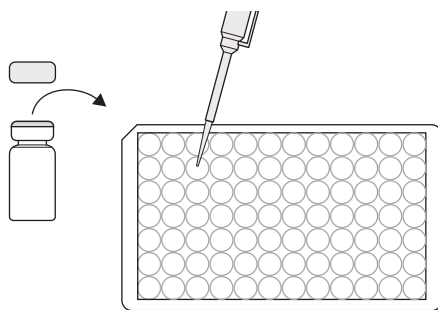

4. Addition of Substrate/Color Solution

Add 100 uL of substrate/color solution to the individual wells successively using a multi-channel pipette or a stepping pipette. Cover the wells with parafilm or tape and mix the contents by moving the strip holder in a rapid circular motion on the benchtop. Be careful not to spill contents. Incubate the strips for 30 min at room temperature.

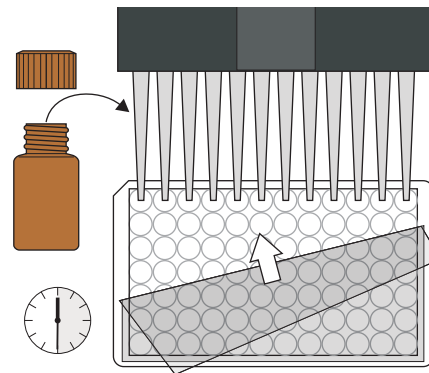

2. Addition of Enzyme Conjugate

Add 50 uL of the enzyme conjugate to the individual wells successively using a multi-channel pipette or a stepping pipette. Cover and mix for 30 seconds by rotating on benchtop. Incubate for 60 minutes at room temperature.

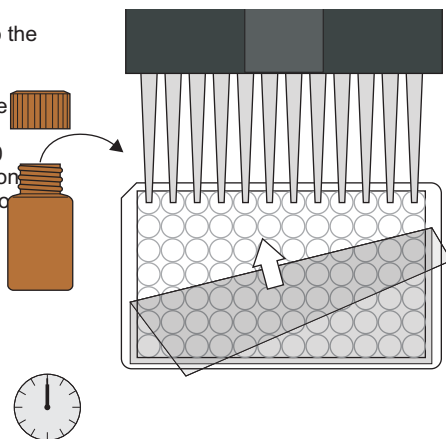

5. Addition of Stopping Solution

Add 100 uL of stop solution to the wells in the same sequence as for the substrate solution using a multi-channel pipette or a stepping pipette.

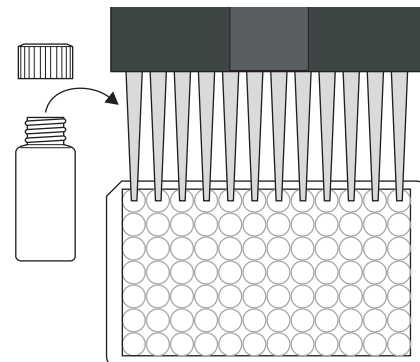

3. Washing of Plates

After incubation, remove the covering and vigorously shake the contents of the wells into a sink. Wash the strips three times with a multi-channel pipette or wash bottle using the diluted 1X washing buffer solution. Please use at least a volume of 250 uL of washing buffer for each well and each washing step. Remaining buffer in the wells should be removed by patting the plate dry on a stack of paper towels.

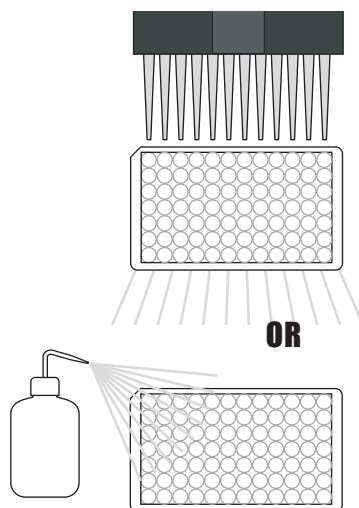

6. Measurement of Color

Read the absorbance at 450 nm using a microplate ELISA reader. Calculate results.

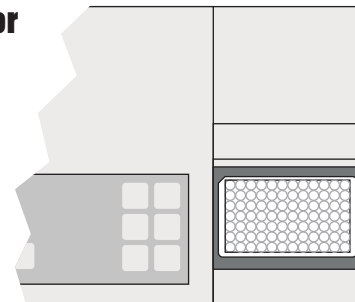

India Contact:

Life Technologies (India) Pvt. Ltd.

306, Aggarwal City Mall, Road No. 44, Pitampura, Delhi – 110034, India

Mobile: +91-98105-21400, Tel: +91-11-42208000, 8111, 8222, Fax: +91-11-42208444

Email: customerservice@lifetechindia.com, www.atzlabs.com; www.lifetechindia.com

Brevetoxin (NSP) Plate, Concise ELISA Procedure

1. Addition of Standards, Samples

Add 50 uL of standard solutions or samples.

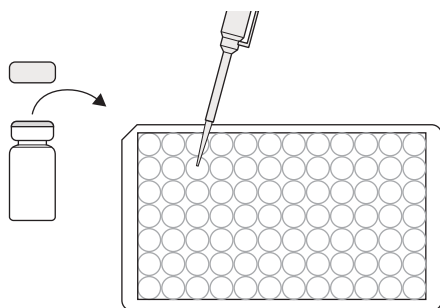

4. Addition of Substrate/Color Solution

Add 100 uL of substrate/color solution. Incubate 30 minutes at room temperature and away from direct sunlight.

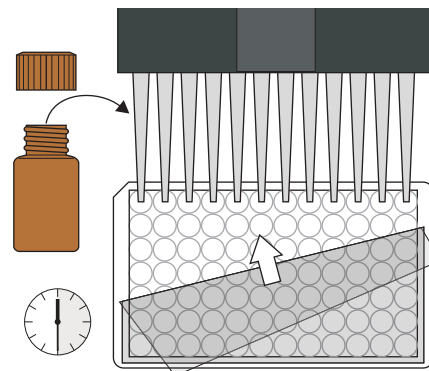

2. Addition of Enzyme Conjugate

Add 50 uL of enzyme conjugate. Cover and mix for 30 seconds by rotating on benchtop. Incubate for 60 minutes at room temperature.

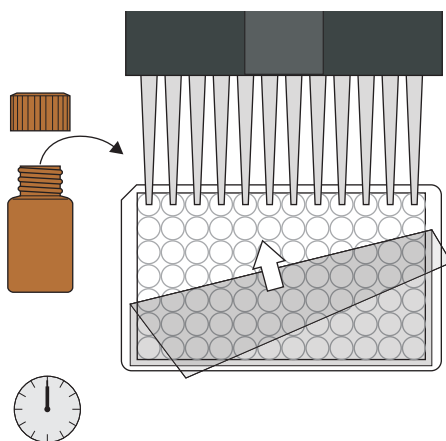

5. Addition of Stopping Solution

Add 100 uL of stop solution.

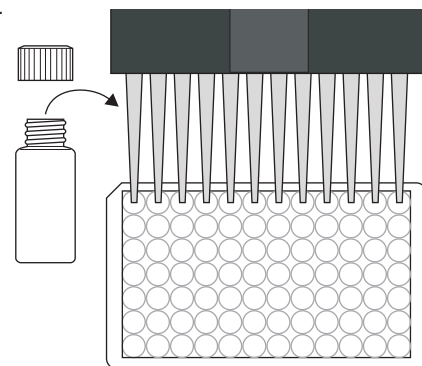

3. Washing of Plates

Wash the plates three times with 250 uL of diluted 1X washing buffer.

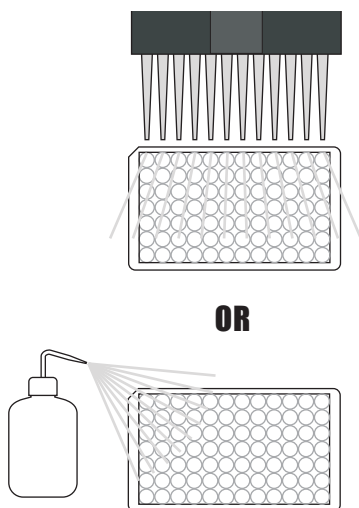

6. Measurement of Color

Measure color at 450 nm. Calculate results.

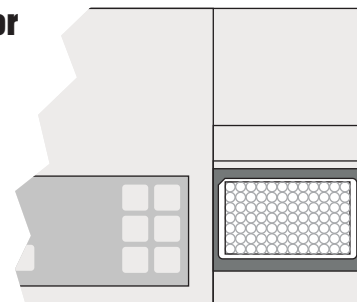

India Contact:

Life Technologies (India) Pvt. Ltd.

306, Aggarwal City Mall, Road No. 44, Pitampura, Delhi – 110034, India

Mobile: +91-98105-21400, Tel: +91-11-42208000, 8111, 8222, Fax: +91-11-42208444

Email: customerservice@lifetechindia.com, www.atzlabs.com; www.lifetechindia.com

Safety Data Sheet

Section 1: Product and Company Identification

1.1 Product Identifiers:

Product Name: Brevetoxin (NSP) ELISA Plate Kit

Product Code: 520026

1.2 Identified Use: Determination of Brevetoxin (NSP) in samples. **Restrictions on Use:** For research use only.

1.3 Company: Abraxis, Inc., 124 Railroad Drive, Warminster, PA 18974 USA, info@abraxiskits.com +1(215) 357-3911, FAX +1(215) 357-5232

1.4 Emergency Telephone Number: +1(215) 357-3911

Section 2: Hazard(s) Identification

2.1 Classification of the mixture:

GHS Classification in accordance with 29 CFR 1910 (OSHA HCS)

Flammable liquids (Category 2), H225 Highly flammable liquid and vapor

Acute toxicity, Oral (Category 3), H301 Toxic if swallowed

Acute toxicity, Inhalation (Category 3), H331 Toxic if inhaled

Acute toxicity, Dermal (Category 3), H311 Toxic in contact with skin

Specific target organ toxicity - single exposure (Category 1), H370 Causes damage to organs

HMIS Rating: Health hazard: 2, Chronic Health Hazard: *, Flammability: 3, Physical Hazard 0

NFPA Rating: Health hazard: 2, Fire Hazard: 3, Reactivity Hazard: 0

2.2 GHS Label elements, including precautionary statements:

Pictogram(s)



Signal word: Danger

Hazard statement(s):

H225 Highly flammable liquid and vapor.

H301 + H311 + H331 Toxic if swallowed, in contact with skin, or if inhaled

H370 Causes damage to organs.

Precautionary statement(s):

P210 Keep away from heat/sparks/open flames/hot surfaces. No smoking.

P233 Keep container tightly closed.

P240 Ground/bond container and receiving equipment.

P241 Use explosion-proof electrical/ventilating/lighting equipment.

P242 Use only non-sparking tools.

P243 Take precautionary measures against static discharge.

P260 Do not breathe dust/fume/gas/mist/vapors/ spray.

P264 Wash skin thoroughly after handling.

P270 Do not eat, drink or smoke when using this product.

P271 Use only outdoors or in a well-ventilated area.

P280 Wear protective gloves/eye protection/face protection.

P301 + P310 + P330 IF SWALLOWED: Immediately call a POISON CENTER or doctor/physician. Rinse mouth.

P303 + P361 + P353 IF ON SKIN (or hair): Take off immediately all contaminated clothing. Rinse skin with water/shower.

P304 + P340 + P311 IF INHALED: Remove person to fresh air and keep comfortable for breathing. Call a POISON CENTER or doctor/physician.

P307 + P311 If exposed: Call a POISON CENTER or doctor/physician.

P362 Take off contaminated clothing and wash before reuse.

P370 + P378 In case of fire: Use dry sand, dry chemical or alcohol-resistant foam to extinguish.

P403 + P233 Store in a well-ventilated place. Keep container tightly closed.

P403 + P235 Store in a well-ventilated place. Keep cool.

P405 Store locked up.

P501 Dispose of contents/ container to an approved waste disposal plant.

2.3 Hazards not otherwise classified (HNOC) or not covered by GHS: None known.

2.4 Unknown acute toxicity: None known.

Section 3: Composition / Information on Ingredients

3.2 Mixtures: Mixture of the hazardous substance(s) listed below, with nonhazardous additions.

Hazardous component(s):

Name and Synonym(s): Methyl alcohol, MeOH, Methanol Formula: CH₄O Molecular weight: 32.04 g/mol

CAS No.: 67-56-1 EC-No.: 200-659-6

Classification: Flammable Liquid 2, Acute Toxicity 3; STOT SE 1; H225, H301 + H311 + H331, H370

Percentage in Mixture: 8 %

For full text of H-Statements mentioned in this Section, see Section 2.

Section 4: First Aid Measures

4.1 Description of first aid measures: Consult a physician. Show this safety data sheet to the doctor in attendance. Move out of dangerous area.

If inhaled: If breathed in, move person into fresh air. If not breathing, give artificial respiration. Consult a physician.

In case of skin contact: Wash off with soap and plenty of water. Take victim immediately to hospital. Consult a physician.

In case of eye contact: Rinse thoroughly with plenty of water for at least 15 minutes and consult a physician.

If swallowed: Do NOT induce vomiting. Never give anything by mouth to an unconscious person. Rinse mouth with water. Consult a physician.

4.2 Most important symptoms and effects, both acute and delayed: The most important known symptoms and effects are described in the labelling (see section 2.2) and/or in section 11

4.3 Indication of any immediate medical attention and special treatment needed: No data available. Treat symptomatically.

Section 5: Fire-fighting Measures

5.1 Suitable extinguishing media: Dry powder or sand **Unsuitable extinguishing media:** Do NOT use water jet

5.2 Special hazards arising from the substance or mixture: Carbon oxides

5.3 Advice for firefighters: Wear self-contained breathing apparatus for fire-fighting if necessary.

5.4 Further information: Use water spray to cool unopened containers.

Section 6: Accidental Release Measures

6.1 Personal precautions, protective equipment and emergency procedures: Use personal protective equipment (see section 8). Avoid dust formation. Avoid breathing vapors, mist, dust, or gas. Ensure adequate ventilation. Remove all sources of ignition. Evacuate personnel to safe areas.

6.2 Environmental precautions: Prevent further leakage or spillage if safe to do so. Do not let product enter drains. Discharge into the environment must be avoided.

6.3 Methods and materials for containment and cleaning up: Contain spillage. Solids (if applicable): Pick up and arrange disposal without creating dust. Sweep up and shovel. Liquids (if applicable): Absorb with non-combustible liquid-binding material (sand, earth, diatomite, vermiculite). Keep in suitable, closed containers for disposal.

6.4 Reference to other sections: For information on safe handling see section 7.

For information on personal protection see section 8.

For information on disposal see section 13.

Section 7: Handling and Storage

7.1 Precautions for safe handling: See section 2. Avoid inhalation of vapors or mist, and avoid contact with skin and eyes. Wear appropriate personal protective equipment. Use explosion-proof equipment. Keep away from sources of ignition. Do not eat, drink, or smoke in work area. Take measures to prevent the buildup of electrostatic charge.

7.2 Precautions for safe storage: Keep container(s) tightly closed in a dry, well-ventilated place. Protect from physical damage. Opened containers must be carefully resealed and kept upright to prevent leakage. See label or product insert for appropriate storage temperature and additional specific information. Storage class (TRGS 510): Flammable liquids.

7.3 Specific end use(s): Other than use(s) specified in section 1, no other uses are stipulated.

Section 8: Exposure Controls / Personal Protection

8.1 Control parameters:

Component(s) with workplace control parameters

Methanol, CAS No. 67-56-1

Value	Control parameters	Basis
TWA	200.000000 ppm	USA. ACGIH Threshold Limit Values (TLV)
Headache Nausea Dizziness Eye damage		

Substances for which there is a Biological Exposure Index or Indices (see BEI section) Danger of cutaneous absorption		
STEL	250.000000 ppm	USA. ACGIH Threshold Limit Values (TLV)
Headache Nausea Dizziness Eye damage Substances for which there is a Biological Exposure Index or Indices (see BEI section) Danger of cutaneous absorption		
TWA	200.000000 ppm; 260.000000 mg/m ³	USA. NIOSH Recommended Exposure Limits
Potential for dermal absorption		
ST	250.000000 ppm; 325.000000 mg/m ³	USA. NIOSH Recommended Exposure Limits
Potential for dermal absorption		
TWA	200.000000 ppm; 260.000000 mg/m ³	USA. Occupational Exposure Limits; (OSHA) - Table Z-1 Limits for Air Contaminants
The value in mg/m ³ is approximate		
TWA	200 ppm; 260 mg/m ³	USA. NIOSH Recommended Exposure Limits
Potential for dermal absorption		
ST	250 ppm; 325 mg/m ³	USA. NIOSH Recommended Exposure Limits
Potential for dermal absorption		
TWA	200 ppm; 260 mg/m ³	USA. Occupational Exposure Limits; (OSHA) - Table Z-1 Limits for Air Contaminants
The value in mg/m ³ is approximate		
STEL	250 ppm; 325 mg/m ³	USA. OSHA - TABLE Z-1 Limits for Air Contaminants - 1910.1000
Skin notation		
TWA	200 ppm; 260 mg/m ³	USA. OSHA - TABLE Z-1 Limits for Air Contaminants - 1910.1000
Skin notation		

Biological occupational exposure limits

Methanol, CAS No. 67-56-1

Parameters	Value	Biological specimen	Basis
Methanol	15.0000 mg/l	Urine	ACGIH – Biological Exposure Indices (BEI)
End of shift (As soon as possible after exposure ceases)			

Derived No Effect Level (DNEL)

Methanol, CAS No. 67-56-1

Application area	Exposure routes	Health effect	Value
Workers	Skin contact	Long-term systemic effects, Acute systemic effects	40mg/kg BW/d
Consumers	Skin contact	Long-term systemic effects, Acute systemic effects	8mg/kg BW/d
Consumers	Ingestion	Long-term systemic effects, Acute systemic effects	8mg/kg BW/d
Workers	Inhalation	Acute systemic effects, Acute local effects, Long-term systemic effects, Long-term local effects	260 mg/m ³
Consumers	Inhalation	Acute systemic effects, Acute local effects, Long-term systemic effects, Long-term local effects	50 mg/m ³

Predicted No Effect Concentration (PNEC)

Methanol, CAS No. 67-56-1

Compartment	Value
Soil	23.5 mg/kg
Marine water	15.4 mg/l
Fresh water	154 mg/l
Fresh water sediment	570.4 mg/kg
Onsite sewage treatment plant	100 mg/kg

8.2 Exposure controls:

Appropriate engineering controls: Provide adequate ventilation. Handle in accordance with good industrial hygiene and safety practice. Wash hands before breaks and at the end of workday. Keep away from food and beverages.

Personal protective equipment

Eye protection: Use equipment for eye protection tested and approved under appropriate government standards such as NIOSH (US) or EN 166 (EU).

Skin protection: Handle with chemical resistant gloves. Gloves must be inspected prior to use. Use proper glove removal technique (without touching glove's outer surface) to avoid skin contact with this product. Dispose of contaminated gloves after use in accordance with applicable laws and good laboratory practices. Wash and dry hands.

Respiratory protection: Use a chemical fume hood or approved respiratory protection equipment.

Body protection: Lightweight, protective clothing to prevent skin exposure.

Section 9: Physical and Chemical Properties

9.1 Information on basic physical and chemical properties of mixture

Appearance: Multiple

Odor: Characteristic

Odor Threshold: No data available

pH: Multiple

Melting point/freezing point: No data available

Initial boiling point and boiling range: No data available

Flash point: No data available

Evaporation rate: No data available

Flammability (solid, gas): No data available

Upper/lower flammability or explosive limits: No data available

Vapor pressure: No data available

Vapor density: No data available

Relative density: No data available

Water solubility: Various

Partition coefficient: n-octanol/water: No data available

Auto-ignition temperature: Not applicable

Decomposition temperature: No data available

Viscosity: No data available

Explosive properties: No data available

Oxidizing properties: No data available

9.2 Other information: No data available

Section 10: Stability and Reactivity

10.1 Reactivity: No data available

10.2 Chemical stability: Stable under recommended storage conditions.

10.3 Possibility of hazardous reactions: No data available

10.4 Conditions to avoid: Keep away from open flame, hot surfaces, heat sources, and sources of ignition.

10.5 Incompatible materials: Acid chlorides, acid anhydrides, strong oxidizing agents, alkali metals, reducing agents, acids, peroxides

10.6 Hazardous decomposition products: No data available. In the event of fire: see section 5.

Section 11: Toxicological Information

11.1 Information on toxicological effects

To the best of our knowledge, the chemical, physical, and toxicological properties of this product have not been thoroughly investigated.

Acute toxicity (Methanol, CAS No. 67-56-1):

Inhalation LC50 Inhalation - Rat - 4 h - 128.2 mg/l; LC50 Inhalation - Rat - 6 h - 87.6 mg/l; LD50 Dermal - Rabbit - 17,100 mg/kg

Ingestion LDLO Oral - Human - 143 mg/kg (Lungs, Thorax, or Respiration:Dyspnea. Ingestion may cause gastrointestinal irritation, nausea, vomiting and diarrhea); LD50 Oral - Rat - 1,187 - 2,769 mg/kg

Skin contact Rabbit skin—no irritation

Eye contact Rabbit eye—no irritation

Respiratory or skin sensitization Maximization Test (GPMT)(OECD Test Guideline 406)--Guinea pig--does not cause skin sensitization

Aspiration hazard No data available

Mutagenicity (Methanol, CAS No. 67-56-1): Ames test (*S. typhimurium*)--Result: negative; *in vitro* assay (fibroblasts)--Result: negative; *in vivo* mammalian bone-marrow cytogenetic test, chromosomal analysis (mouse, male and female)--Result: negative

Carcinogenicity:

IARC: No component of this product present at levels greater than or equal to 0.1% is identified as probable, possible or confirmed human carcinogen by IARC.

ACGIH: No component of this product present at levels greater than or equal to 0.1% is identified as a carcinogen or potential carcinogen by ACGIH.

NTP: No component of this product present at levels greater than or equal to 0.1% is identified as a known or anticipated carcinogen by NTP.

OSHA: No component of this product present at levels greater than or equal to 0.1% is identified as a carcinogen or potential carcinogen by OSHA.

Teratogenicity: No data available

Reproductive/fertility toxicity: Damage to fetus not classifiable

Specific target organ toxicity, single exposure (Methanol, CAS No. 67-56-1): Causes damage to organs

Specific target organ toxicity, repeated exposure: The substance or mixture is not classified as specific target organ toxicant, repeated exposure.

Additional information (Methanol, CAS No. 67-56-1): RTECS: PC1400000 Effects due to ingestion may include headache, dizziness, drowsiness, metabolic acidosis, coma, seizures. Methanol may be fatal or cause blindness if swallowed. Stomach - Irregularities - Based on Human Evidence

Section 12: Ecological Information

12.1 Toxicity: No data available

12.2 Persistence and degradability: Readily biodegradable

12.3 Bioaccumulative potential: No data available

12.4 Mobility in soil: No data available

12.5 Results of PBT and vPvB assessment: No data available

12.6 Other adverse effects: An environmental hazard cannot be excluded in the event of unprofessional handling or disposal.

Section 13: Disposal Considerations**13.1 Waste treatment methods**

Product: All waste must be handled and disposed according to local, state, and federal regulations. Avoid disposing large volumes in sewer.

Contaminated packaging: All waste must be handled and disposed according to local, state, and federal regulations.

Refer to sections 7 and 8 for safe handling guidance.

Section 14: Transport Information

DOT, Land Transport ADR/RID (cross-border), Maritime Transport IMDG, Air Transport ICAO-TI and IATA-DGR

UN Number: 3316

UN Proper shipping name: Chemical Kit, (contains Methanol)

Transport hazard class(es): 9

Packing group: III

Environmental hazard: See section 12

Bulk transport: Excepted/Limited quantity

Special considerations: See section 7 for handling

Section 15: Regulatory Information

EU Regulations, Hazard Symbol(s): Methanol: T (Toxic), F (Flammable)

Safety Phrases:

Methanol: S 7 / 16 / 36 / 37 / 45, Keep container tightly closed. Keep away from sources of ignition, no smoking. Wear suitable protective clothing and gloves. In case of accident or if you become ill, seek medical advice immediately (show product label).

SARA Title III, Section 302 Components: No chemicals in this material are subject to the reporting requirements of SARA Title III, Section 302.

SARA Title III, Section 313 Components: Methanol, CAS No. 67-56-1

SARA 311/312 Hazards: Methanol, CAS No. 67-56-1: Fire Hazard, Acute Health Hazard, Chronic Health Hazard

State Right-to-Know

Massachusetts: Methanol, CAS No. 67-56-1

Pennsylvania: Methanol, CAS No. 67-56-1

New Jersey: Methanol, CAS No. 67-56-1

California Prop. 65 Components: WARNING: This product contains a chemical known to the State of California to cause birth defects or other reproductive harm. Methanol, CAS No. 67-56-1

Section 16: Other information

This information is based on our present knowledge. While Abraxis , Inc. believes that the data contained herein are factual and the opinions expressed represent a best effort to present accurate information, the data are not to be taken as a warranty or representation for which Abraxis , Inc. assumes legal responsibility. The information shall not be taken as being all-inclusive and is to be used only as a guide. The data are offered solely for the user's consideration, investigation, and verification. These suggestions should not be confused with either state, municipal, or insurance requirements, or with national safety codes and constitute no warranty. Any use of these data and information must be determined by the user to be in accordance with applicable federal, state, and local regulations.

All materials and mixtures may present unknown hazards and should be used with caution. Since Abraxis , Inc. cannot control the methods, volumes, or conditions of use of this product, Abraxis , Inc. shall not be held liable for any damages or losses resulting from the handling or from contact with the product as described herein. An individual technically qualified to handle potentially hazardous chemicals must supervise the use of this material. This product is sold for research use only. It is not for any human or animal therapeutic or clinical diagnostic use.

Date this SDS was prepared: 5/20/2016

Version: 3

Changes from previous version: Abraxis, LLC changed to Abraxis, Inc.