

## Anatoxin-a Receptor-Binding Assay\* (Microtiter Plate)

Receptor-Binding Assay for the Determination  
 of Anatoxin-a in Fresh Water

Product No. 520050

### Importance of Anatoxin-a Determination

Anatoxin-a is an alkaloid neurotoxin produced by some species of cyanobacteria (blue-green algae). It is one of the most toxic of the cyanobacterial toxins. In humans and other animals, the skeletal neuromuscular junction constitutes a primary target for Anatoxin-a (Anatoxin-a can also cross the blood-brain barrier). The neuromuscular junction is specialized for the rapid transmission of neuronal information from the pre-synaptic nerve terminal to the post-synaptic muscle fiber. This transmission is mediated by the synchronous release of the neurotransmitter acetylcholine (ACh), which activates nicotinic acetylcholine receptors (nAChRs) in the muscle endplate, triggering a series of events that lead to muscle contraction. Most ACh molecules are hydrolyzed by acetylcholinesterases, which are highly concentrated at the neuromuscular junction. Anatoxin-a functions as an agonist of nAChRs, like ACh, but is about 20 times more potent. Unlike ACh, it is not degraded by acetylcholinesterases and produces sustained depolarization of the muscle endplate, causing overstimulation of the muscles, leading to muscle fatigue and ultimately paralysis. Symptoms begin within 5 minutes of ingestion of Anatoxin-a and progress rapidly, resulting in cyanosis, convulsions, cardiac arrhythmia, and respiratory paralysis, which ultimately results in death due to suffocation.

Humans and other animals may be exposed to Anatoxin-a through ingestion of contaminated water, through drinking or during recreational activities in which water is swallowed. Due to the potential for serious harm and even death, many countries are expanding monitoring programs to include Anatoxin-a and are establishing regulations regarding the amount of Anatoxin-a in drinking and recreational waters. New Zealand is among those taking regulatory action, establishing a 6.0 µg/L provisional maximum acceptable value (MAV) for Anatoxin-a.

The Abraxis Anatoxin-a Receptor-Binding Assay can be performed in approximately 3.5 hours. Only a few milliliters of sample are required.

### Performance Data

#### Test sensitivity:

The limit of detection for Anatoxin-a is 10 ng/mL. The concentration of residue necessary to cause 50% inhibition (50% B/B<sub>0</sub>) is approximately 82.1 ng/mL. Determinations closer to the middle of the calibration range of the test yield the most accurate results.

The assay range is 10 ng/mL to 500 ng/mL. Sample concentration may be performed for samples requiring a lower limit of detection (0.2 ng/mL to 10 ng/mL range). SPE column purchasing information and sample concentration technical bulletin are available from Abraxis by request.

#### Test reproducibility:

Coefficients of variation (CVs) for standards: <10%; for samples: <15% (based on absorbance).

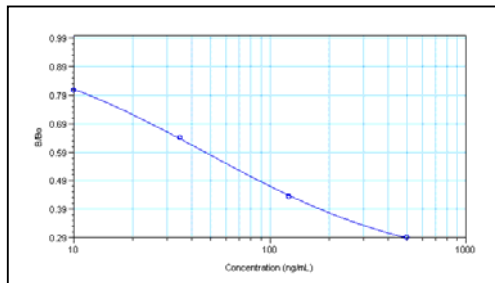

For demonstration purposes only. Not for use in sample interpretation.

### References:

\**Procédé de fabrication d'un support d'analyse et utilisation pour la détection des toxines.* French priority patent application No. 1150586, January 25, 2011 and International patent application No. FR2012050157, January 24, 2012. Licensed exclusively by Abraxis.

### General Limited Warranty:

Abraxis LLC warrants the products manufactured by the Company against defects and workmanship when used in accordance with the applicable instructions for a period not to extend beyond the product's printed expiration date. **Abraxis makes no other warranty, expressed or implied. There is no warranty of merchantability or fitness for a particular purpose.**

For ordering or technical assistance contact:

India Contact:

**Life Technologies (India) Pvt. Ltd.**

306, Aggarwal City Mall, Road No. 44, Pitampura, Delhi - 110034, India

Mobile: +91-98105-21400, Tel: +91-11-42208000, 8111, 8222, Fax: +91-11-42208444

Email: [customerservice@lifetechindia.com](mailto:customerservice@lifetechindia.com), [www.atzlabs.com](http://www.atzlabs.com); [www.lifetechindia.com](http://www.lifetechindia.com)

### 1. General Description

The Abraxis Anatoxin-a Receptor-Binding Assay is a patented\* receptor-binding assay for the detection of Anatoxin-a in fresh water samples. This test is suitable for the quantitative and/or qualitative detection of Anatoxin-a. Positive samples should be confirmed by HPLC/MS, GC/MS, or other conventional methods.

### 2. Safety Instructions

The standard solutions in this test kit contain small amounts of Anatoxin-a. In addition, the substrate solution contains tetramethylbenzidine and the stop solution contains diluted sulfuric acid. Avoid contact of these solutions with skin and mucous membranes. If these reagents come in contact with skin, wash thoroughly with water.

### 3. Storage and Stability

The Anatoxin-a Receptor-Binding Assay Kit should be stored in the refrigerator (4–8°C). The solutions must be allowed to reach room temperature (20–25°C) before use. Reagents may be used until the expiration date on the box.

### 4. Test Principle

The test is a receptor-binding assay based on the affinity of Anatoxin-a for nicotinic acetylcholine receptors (nAChRs). Anatoxin-a, when present in a sample, will compete with the biotinylated alpha-bungarotoxin for the acetylcholine binding sites of nAChRs, from purified *Torpedo* electrocyte membranes, which were coated on the microtiter plate. After a washing step, a streptavidin-HRP solution is added to allow for the colorimetric detection of the biotinylated alpha-bungarotoxin bound on the receptor. After a second washing step, the substrate solution is added and a color signal is produced. The intensity of the blue color is inversely proportional to the concentration of Anatoxin-a present in the sample. The color reaction is stopped after a specified time and the color (yellow) is evaluated using a microplate photometer. The concentrations of the samples are determined by interpolation using the standard curve constructed with each run.

### 5. Limitations of the Anatoxin-a Receptor-Binding Assay, Possible Test Interference

Numerous organic and inorganic compounds commonly found in samples have been tested and found not to interfere with this test. However, due to the high variability of compounds that might be found in environmental samples, test interferences caused by matrix effects cannot be completely excluded.

Anatoxin-a will degrade when exposed to natural and artificial light and/or high pH conditions. Samples which have been exposed to natural or artificial light and/or preserved with reagents which raise the natural sample pH may produce results which are biased low. See Section C, Sample Collection and Handling, for appropriate sample handling information.

Mistakes in handling the test can also cause errors. Possible sources for such errors can include:

a) inadequate storage conditions of the test kit, b) incorrect pipetting sequence or inaccurate volumes of the reagents, c) too long or too short incubation times, and d) inadequate temperatures during incubations (<35°C or >40°C during Standard/Sample, Biotinylated Alpha-Bungarotoxin, and Streptavidin incubations and <20°C or >25°C during Color incubation).

The Abraxis Anatoxin-a Receptor-Binding Assay kit provides screening results. As with any analytical technique (GC, HPLC, etc.), positive samples requiring regulatory action should be confirmed by an alternative method.

## Working Instructions

### A. Materials Provided

1. Nicotinic Acetylcholine Receptor (nAChR) coated microtiter plate, 12 strips of 8 wells in a resealable pouch
2. Standard Assay Buffer, 6 mL
3. Sample Assay Buffer, 6 mL
4. Anatoxin-a Standards (5): 0, 10, 35, 125, and 500 ng/mL (ppb), 1 mL each
5. Biotinylated Alpha-Bungarotoxin Solution, 6 mL
6. Streptavidin-HRP Conjugate Solution, 16 mL
7. Sample Diluent, 30 mL
8. Wash Solution (5X) Concentrate, 100 mL, must be diluted before use, see Test Preparation (Section C)
9. Color (Substrate) Solution (TMB), 16 mL
10. Stop Solution, 12 mL
11. Adhesive Film Plate Cover

### B. Additional Materials (not included with the test kit)

1. Micro-pipettes with disposable plastic tips (20-200 µL)
2. Multi-channel pipette or stepping pipette (50-250 µL) with disposable plastic tips
3. Deionized or distilled water
4. Graduated cylinder
5. Container with 500 mL capacity (for 1X diluted Wash Solution, see Test Preparation, Section C)
6. Timer
7. Paper towels or equivalent absorbent material
8. Incubator capable of maintaining 37°C
9. Microtiter plate reader (wave length 450 nm)

### C. Sample Collection and Handling

Collect water samples in amber glass sample containers and store refrigerated for up to 5 days. Samples which must be held for more than 5 days should be stored frozen. Samples should be protected from exposure to natural and artificial light, as light exposure will cause degradation of Anatoxin-a. Do not preserve samples with reagents which will raise the natural sample pH. If sample pH must be adjusted for extraction or concentration purposes, brief exposure to high pH conditions will not adversely affect results, but prolonged exposure to high pH conditions should be avoided.

If total Anatoxin-a concentration (free and cell-bound) is required, an appropriate cell lysing procedure (freeze and thaw, sonication, QuikLyse™, etc.) must be performed prior to analysis.

If large amounts of organic matter are present, samples may be filtered prior to analysis (PALL Life Sciences Acrodisc® 25 mm Syringe Filters (PALL part number 4612) are recommended). If determining total Anatoxin-a concentration, samples should be lysed prior to filtration to prevent the removal of cell-bound Anatoxin-a, which would cause inaccurate results.

### D. Test Preparation

Micro-pipetting equipment and pipette tips for pipetting the standards and samples are necessary. A multi-channel pipette or a stepping pipette is recommended for adding the Biotinylated Alpha-Bungarotoxin, Streptavidin-HRP Conjugate, substrate (color), and stop solutions in order to equalize the incubation periods of the solutions on the entire microtiter plate. Please use only the reagents and standards from one package lot in one test, as they have been adjusted in combination.

1. Allow the microtiter plate, reagents, and samples to reach room temperature before beginning the test.
2. The microtiter plate consists of 12 strips of 8 wells. The recommended run size is 6 strips or less, as drift may occur. Use of more than 6 strips in an analytical run may cause inaccurate results. Analysis in triplicate is highly recommended.
3. Remove the number of microtiter plate strips required from the foil bag. The remaining strips must be stored in the foil bag with desiccant and zip-locked closed. Store the remaining kit in the refrigerator (4-8°C).
4. The standard solutions, assay buffers, Biotinylated Alpha-Bungarotoxin, Streptavidin-HRP, substrate (color), and stop solutions are ready to use and do not require any further dilutions.
5. Dilute the wash buffer concentrate at a ratio of 1:5 with deionized or distilled water. If using the entire bottle (100 mL), add to 400 mL of deionized or distilled water.
6. The stop solution must be handled with care as it contains diluted H<sub>2</sub>SO<sub>4</sub>.
7. The adhesive film plate cover should be used to cover the wells during the incubation periods. Wells should be sealed closed to prevent evaporative loss. The cover can be used for multiple runs; do not discard the backing – replace on the adhesive portion of the cover after each use.

### E. Working Scheme

The microtiter plate consists of 12 strips of 8 wells, which can be used individually for the test. The recommended run size is 6 strips or less, as drift may occur. Use of more than 6 strips in an analytical run may cause inaccurate results. Analysis in triplicate is highly recommended. The standards must be run with each test. Never use the values of standards which have been determined in a test performed previously.

#### Standard Assay Buffer

Std 0-Std 4: Standards  
 0; 10; 35; 125; 500 ppb

#### Sample Assay Buffer

Samp1, Samp2, etc.: Samples

	1	2	3	4	5	6	7	8	9	10	11	12
A	Std 0	Std 0	Std 0	Std 1								
B	Std 1	Std 1	Std 1	Std 2								
C	Std 2	Std 2	Std 2	Std 3								
D	Std 3	Std 3	Std 3	Std 4								
E	Samp 1	Samp 1	Samp 1	Samp 2								
F	Samp 2	Samp 2	Samp 2	Samp 3								
G	Samp 3	Samp 3	Samp 3	Samp 4								
H	Samp 4	Samp 4	Samp 4	Samp 5								

### F. Assay Procedure

1. Add 25 µL of the standard assay buffer or 25 µL of the sample assay buffer into the appropriate wells of the test strips according to the working scheme given (gray shading in illustration indicates wells to be used for standards, requiring standard assay buffer, yellow shading indicates wells for samples, requiring sample assay buffer).
2. Add 100 µL of the standard solutions and samples into the appropriate wells of the test strips, containing the appropriate assay buffer, according to the working scheme given. Analysis in triplicate is recommended. Cover the wells with the adhesive film plate cover and mix the contents by moving the strip holder in a circular motion on the benchtop for 60 seconds. Be careful not to spill the contents. Incubate the strips in an incubator at 37°C for 2 hours.
3. Add 50 µL of biotinylated alpha-bungarotoxin solution to the individual wells successively using a multi-channel pipette or a stepping pipette. Cover the wells with the adhesive film plate cover and mix the contents by moving the strip holder in a circular motion on the benchtop for 60 seconds. Be careful not to spill the contents. Incubate in an incubator at 37°C for 30 minutes.
4. Remove the covering and vigorously shake the contents of the wells into a sink. Wash the strips three times using the 1X washing buffer solution. Use at least a volume of 250 µL of washing buffer for each well and each washing step. Remaining buffer in the wells should be removed by patting the plate dry on a stack of paper towels.
5. Add 150 µL of streptavidin-HRP conjugate solution to the individual wells successively using a multi-channel pipette or a stepping pipette. Cover the wells with the adhesive film plate cover and mix the contents by moving the strip holder in a circular motion on the benchtop for 60 seconds. Be careful not to spill the contents. Incubate in an incubator at 37°C for 30 minutes.
6. Remove the covering and vigorously shake the contents of the wells into a sink. Wash the strips three times using the 1X washing buffer solution. Use at least a volume of 250 µL of washing buffer for each well and each washing step. Remaining buffer in the wells should be removed by patting the plate dry on a stack of paper towels.
7. Add 150 µL of substrate (color) solution to the wells using a multi-channel pipette or a stepping pipette. Cover the wells with the adhesive film plate cover and mix the contents by moving the strip holder in a circular motion on the benchtop for 60 seconds. Incubate for 30 minutes at room temperature. Protect the strips from direct sunlight.
8. Add 100 µL of stop solution to the wells using a multi-channel pipette or a stepping pipette in the same sequence as for the substrate solution.
9. Read the absorbance at 450 nm using a microplate ELISA photometer within 15 minutes after the addition of the stopping solution.

### G. Evaluation

The evaluation of the assay can be performed using commercial ELISA evaluation programs (4-Parameter (preferred) or Logit/Log). For manual evaluation, calculate the mean absorbance value for each of the standards (B<sub>i</sub>). Calculate the %B<sub>i</sub>/B<sub>0</sub> for each standard by dividing the mean absorbance value for each standard by the Zero Standard (Standard 0) mean absorbance (B<sub>0</sub>). Construct a standard curve by plotting the %B<sub>i</sub>/B<sub>0</sub> for each standard on the vertical linear (y) axis versus the corresponding Anatoxin-a concentration on the horizontal logarithmic (x) axis on graph paper. %B<sub>i</sub>/B<sub>0</sub> for samples will then yield levels in ppb of Anatoxin-a by interpolation using the standard curve. Samples showing lower concentrations of Anatoxin-a compared to Standard 1 (10 ng/mL) should be reported as containing < 10 ng/mL of Anatoxin-a. Samples showing a higher concentration than Standard 4 (500 ng/mL) should be reported as containing > 500 ng/mL of Anatoxin-a. If a quantitative result is necessary, samples must be diluted further and re-analyzed to obtain accurate results.

# Anatoxin-a RBA Kit, Detailed Procedure

## 1. Addition of Standard Assay buffer and Sample Assay buffer

Add 25  $\mu$ L of standard assay buffer to standard wells and 25  $\mu$ L of sample assay buffer to sample wells. Recommended run size is 6 strips or less.

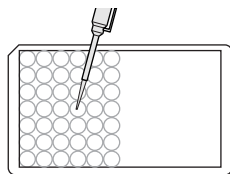

## 2. Addition of Standards, Samples

Add 100  $\mu$ L of the standard solutions and/or samples into the wells of the test strips according to the working scheme given. Analysis in triplicate is recommended. Cover the wells with adhesive plate cover and mix the contents by moving the strip holder in a rapid circular motion on the benchtop for 1 minute. Be careful not to spill contents. Incubate the strips for 2 hours at 37°C.

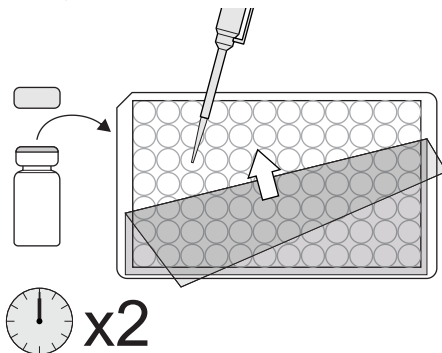

## 3. Addition of Biotinylated Alpha-Bungarotoxin Solution

Add 50  $\mu$ L of the biotinylated alpha-bungarotoxin solution to the individual wells successively using a multi-channel pipette. Cover the wells with adhesive plate cover and mix the contents by moving the strip holder in a rapid circular motion on the benchtop for 1 minute. Be careful not to spill contents. Incubate the strips for 30 minutes at 37°C.

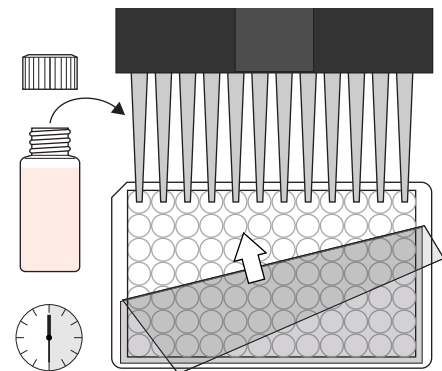

## 4. Washing of Plates

After incubation, remove the covering and vigorously shake the contents of the wells into a sink. Wash the strips three times with a multi-channel pipette using the diluted 1X washing buffer solution. Please use at least a volume of 250  $\mu$ L of washing buffer for each well and each washing step. Remaining buffer in the wells should be removed by patting the plate dry on a stack of paper towels.

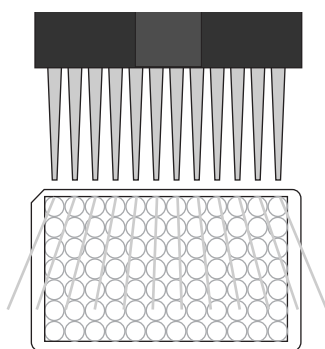

## 5. Addition of Streptavidin-HRP Conjugate

Add 150  $\mu$ L of the streptavidin-HRP conjugate to the individual wells successively using a multi-channel pipette or a stepping pipette. Cover the wells with adhesive plate cover and mix the contents by moving the strip holder in a rapid circular motion on the benchtop for 1 minute. Be careful not to spill contents. Incubate the strips for 30 minutes at 37°C.

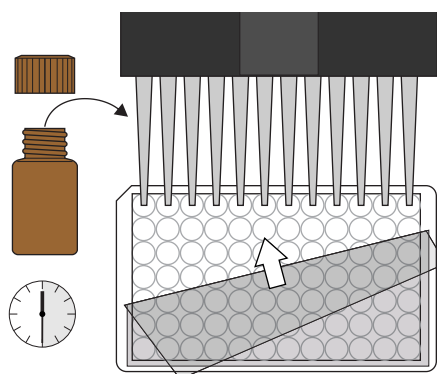

## 6. Washing of Plates

After incubation, remove the covering and vigorously shake the contents of the wells into a sink. Wash the strips three times with a multi-channel pipette or wash bottle using the diluted 1X washing buffer solution. Please use at least a volume of 250  $\mu$ L of washing buffer for each well and each washing step. Remaining buffer in the wells should be removed by patting the plate dry on a stack of paper towels.

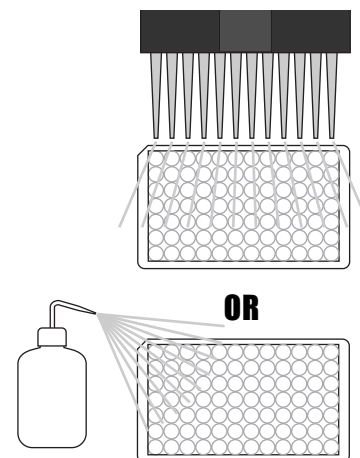

## 7. Addition of Substrate/Color Solution

Add 150  $\mu$ L of substrate/color solution to the individual wells successively using a multi-channel pipette or a stepping pipette. Cover the wells with parafilm or tape and mix the contents by moving the strip holder in a rapid circular motion on the benchtop for 1 minute. Be careful not to spill contents. Incubate the strips for 30 minutes at room temperature.

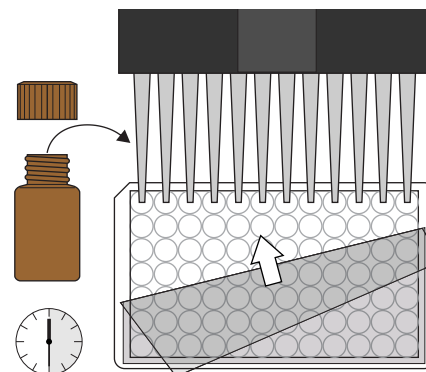

## 8. Addition of Stopping Solution

Add 100  $\mu$ L of stop solution to the wells in the same sequence as for the substrate solution using a multi-channel pipette or a stepping pipette.

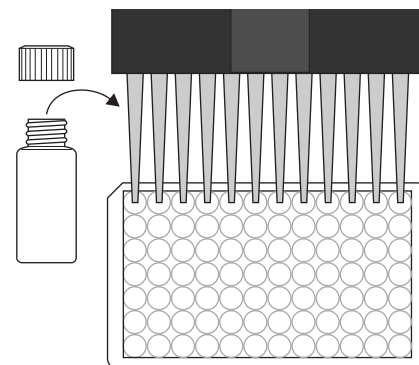

## 9. Measurement of Color

Read the absorbance at 450 nm using a microplate ELISA reader. Calculate results.

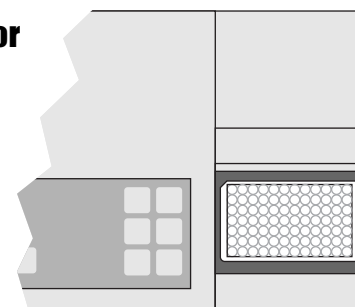

India Contact:

**Life Technologies (India) Pvt. Ltd.**

306, Aggarwal City Mall, Road No. 44, Pitampura, Delhi - 110034, India

Mobile: +91-98105-21400, Tel: +91-11-42208000, 8111, 8222, Fax: +91-11-42208444

Email: customerservice@lifetechindia.com, [www.atzlabs.com](http://www.atzlabs.com); [www.lifetechindia.com](http://www.lifetechindia.com)

# Anatoxin-a RBA Kit, Concise Procedure

## 1. Addition of Standard Assay buffer and Sample Assay buffer

Add 25  $\mu$ L of standard assay buffer to standard wells and 25  $\mu$ L of sample assay buffer to sample wells. Recommended run size of plate is no more than six rows.

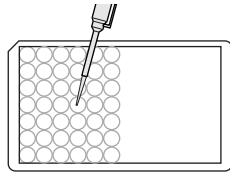

## 2. Addition of Standards, Samples

Add 100  $\mu$ L of the standard solutions and/or samples. Cover and mix for 1 minute. Incubate the strips for 2 hours at 37°C.

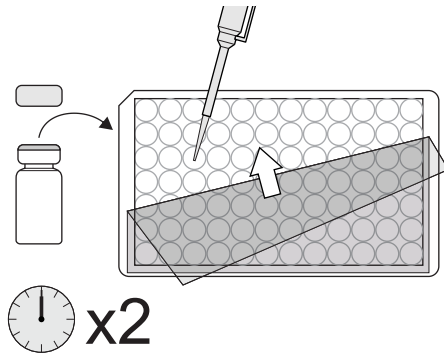

## 3. Addition of Biotinylated Alpha-Bungarotoxin Solution

Add 50  $\mu$ L of the biotinylated alpha-bungarotoxin solution. Cover and mix for 1 minute. Incubate the strips for 30 minutes at 37°C.

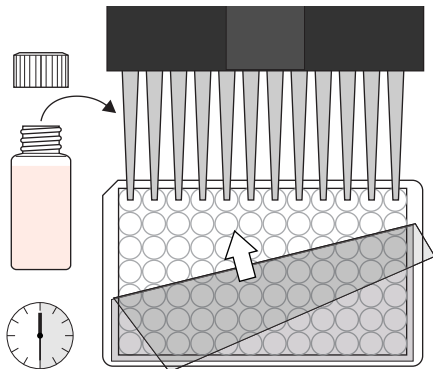

## 4. Washing of Plates

Wash the strips three times with 250  $\mu$ L of diluted 1x washing buffer.

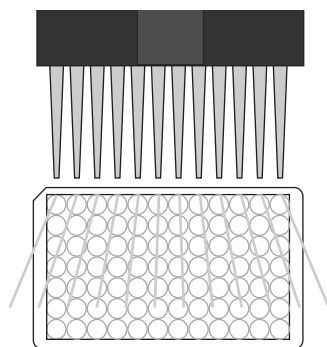

## 5. Addition of Streptavidin-HRP Conjugate

Add 150  $\mu$ L of the streptavidin-HRP conjugate. Cover and mix for 1 minute. Incubate the strips for 30 minutes at 37°C.

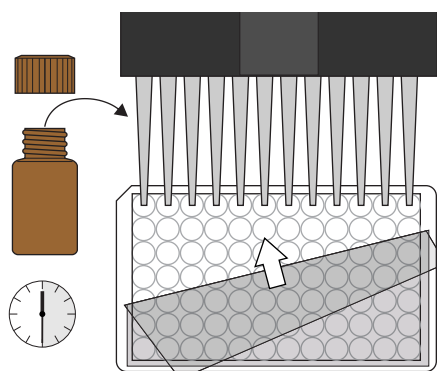

## 6. Washing of Plates

Wash the strips three times with 250  $\mu$ L of diluted 1X washing buffer.

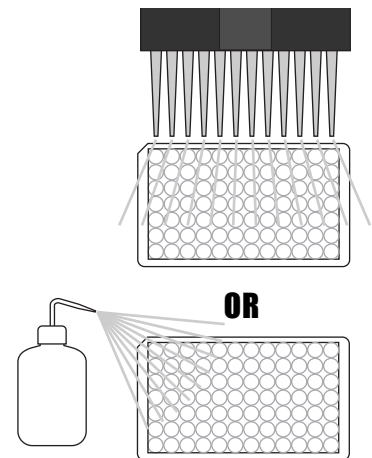

## 7. Addition of Substrate/Color Solution

Add 150  $\mu$ L of substrate/color solution. Incubate 30 minutes at room temperature and away from direct sunlight.

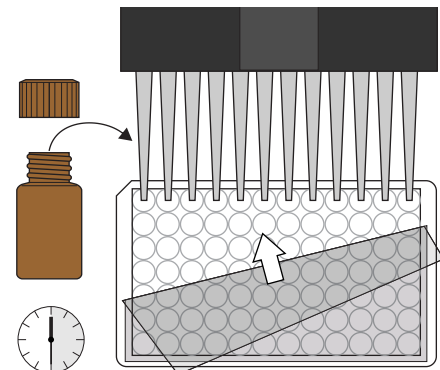

## 8. Addition of Stopping Solution

Add 100  $\mu$ L of stop solution.

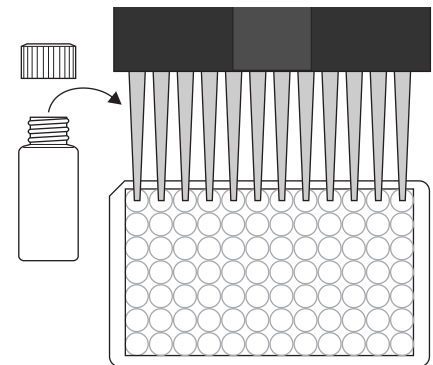

## 9. Measurement of Color

Read the absorbance at 450 nm. Calculate results.

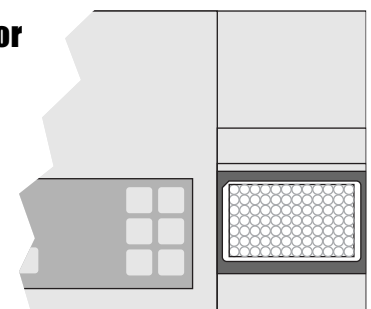

India Contact:

**Life Technologies (India) Pvt. Ltd.**

306, Aggarwal City Mall, Road No. 44, Pitampura, Delhi - 110034, India

Mobile: +91-98105-21400, Tel: +91-11-42208000, 8111, 8222, Fax: +91-11-42208444

Email: customerservice@lifetechindia.com, [www.atzlabs.com](http://www.atzlabs.com); [www.lifetechindia.com](http://www.lifetechindia.com)



# Safety Data Sheet

## Section 1: Product and Company Identification

### 1.1 Product Identifiers:

**Product Name:** Anatoxin-a RBA Kit

**Product Code:** 520050

**1.2 Identified Use:** Determination of Anatoxin-a in samples. **Restrictions on Use:** For research use only.

**1.3 Company:** Abraxis, Inc., 124 Railroad Drive, Warminster, PA 18974 USA, [info@abraxiskits.com](mailto:info@abraxiskits.com) +1(215) 357-3911, FAX +1(215) 357-5232

**1.4 Emergency Telephone Number:** +1(215) 357-3911

## Section 2: Hazard(s) Identification

**2.1 Classification of the mixture:** Not a hazardous mixture.

**2.2 GHS Label elements, including precautionary statements:** Not applicable.

**2.3 Hazards not otherwise classified (HNOC) or not covered by GHS:** None known.

**2.4 Unknown acute toxicity:** None known.

## Section 3: Composition / Information on Ingredients

**3.2 Mixtures:** *Contains no hazardous ingredients at levels requiring disclosure by the OSHA Hazard Communication Standard (29 CFR 1910.1200), however it contains minor amounts of materials considered hazardous. We recommend handling all substances with caution.*

## Section 4: First Aid Measures

**4.1 Description of first aid measures:** Consult a physician. Show this safety data sheet to the doctor in attendance. Move out of dangerous area.

**If inhaled:** If breathed in, move person into fresh air. If not breathing, give artificial respiration. Consult a physician.

**In case of skin contact:** Wash off with soap and plenty of water. Consult a physician.

**In case of eye contact:** Rinse thoroughly with plenty of water for at least 15 minutes and consult a physician.

**If swallowed:** Never give anything by mouth to an unconscious person. Rinse mouth with water. Consult a physician.

**4.2 Most important symptoms and effects, both acute and delayed:** No data available

**4.3 Indication of any immediate medical attention and special treatment needed:** No data available. Treat symptomatically.

## Section 5: Fire-fighting Measures

**5.1 Suitable extinguishing media:** Use an extinguishing agent suitable for the surrounding fire.

**5.2 Special hazards arising from the substance or mixture:** None known

**5.3 Advice for firefighters:** Wear self-contained breathing apparatus for fire-fighting if necessary.

**5.4 Further information:** No data available

## Section 6: Accidental Release Measures

**6.1 Personal precautions, protective equipment and emergency procedures:** Use personal protective equipment (see section 8). Avoid dust formation. Avoid breathing vapors, mist, dust, or gas. Ensure adequate ventilation. Evacuate personnel to safe areas.

**6.2 Environmental precautions:** Prevent further leakage or spillage if safe to do so. Do not let product enter drains. Discharge into the environment must be avoided.

**6.3 Methods and materials for containment and cleaning up:** Solids (if applicable): Pick up and arrange disposal without creating dust. Sweep up and shovel. Liquids (if applicable): Absorb with liquid-binding material (sand, diatomite, acid binders, universal binders, sawdust). Keep in suitable, closed containers for disposal.

**6.4 Reference to other sections:** For information on safe handling see section 7.

For information on personal protection see section 8.

For information on disposal see section 13.

## Section 7: Handling and Storage

**7.1 Precautions for safe handling:** See section 2. Avoid inhalation of vapors and contact with skin and eyes. Wear appropriate personal protective equipment. Do not eat, drink, or smoke in work area.

**7.2 Precautions for safe storage:** Keep container(s) tightly closed in a dry, well-ventilated place. Protect from physical damage. See label or product insert for appropriate storage temperature and additional specific information.

7.3 Specific end use(s): No data available

## Section 8: Exposure Controls / Personal Protection

**8.1 Control parameters:** Not applicable.

**8.2 Exposure controls:**

**Appropriate engineering controls:** Provide adequate ventilation. Handle in accordance with good industrial hygiene and safety practice. Wash hands before breaks and at the end of workday. Keep away from food and beverages.

**Personal protective equipment:** The usual precautionary measures, including eye/face/skin protection, should be taken when handling any chemical. Avoid contact with eyes, skin, and clothing.

**Eye protection:** As with handling of any chemical, wear approved safety goggles.

**Skin protection:** Handle with gloves. No specific information regarding glove material or thickness is available, but gloves must be impermeable and resistant to the substance being handled. Gloves must be inspected prior to use. Use proper glove removal technique (without touching glove's outer surface) to avoid skin contact with this product. Dispose of contaminated gloves after use in accordance with applicable laws and good laboratory practices. Wash and dry hands.

**Respiratory protection:** As with any chemical, where excessive vapor, mist, or dust may result, use a chemical fume hood or approved respiratory protection equipment.

**Body protection:** Lightweight, protective clothing.

## Section 9: Physical and Chemical Properties

**9.1 Information on basic physical and chemical properties of the mixture**

**Appearance:** Multiple

**Odor:** Characteristic

**Odor Threshold:** No data available

**pH:** Multiple

**Melting point/freezing point:** No data available

**Initial boiling point and boiling range:** No data available

**Flash point:** Not applicable

**Evaporation rate:** No data available

**Flammability (solid, gas):** No data available

**Upper/lower flammability or explosive limits:** No data available

**Vapor pressure:** No data available

**Vapor density:** No data available

**Relative density:** No data available

**Water solubility:** Various

**Partition coefficient: n-octanol/water:** No data available

**Auto-ignition temperature:** Not applicable

**Decomposition temperature:** No data available

**Viscosity:** No data available

**Explosive properties:** No data available

**Oxidizing properties:** No data available

**9.2 Other information:** No data available

## Section 10: Stability and Reactivity

**10.1 Reactivity:** No data available

**10.2 Chemical stability:** Stable under recommended storage conditions.

**10.3 Possibility of hazardous reactions:** No data available

**10.4 Conditions to avoid:** No data available

**10.5 Incompatible materials:** No data available

**10.6 Hazardous decomposition products:** No data available. In the event of fire: see section 5.

## Section 11: Toxicological Information

**11.1 Information on toxicological effects**

**Acute toxicity:** Not available. To the best of our knowledge, the chemical, physical, and toxicological properties of this product have not been thoroughly investigated.

**Inhalation:** No data available      **Ingestion:** No data available

**Skin contact:** Irritant to skin and mucous membranes.

**Eye contact:** May cause eye irritation in susceptible persons.

**Respiratory or skin sensitization:** No data available

**Aspiration hazard:** No data available

**Mutagenicity:** No data available

**Carcinogenicity**

IARC: No component of this product present at levels greater than or equal to 0.1% is identified as probable, possible or confirmed human carcinogen by IARC.

ACGIH: No component of this product present at levels greater than or equal to 0.1% is identified as a carcinogen or potential carcinogen by ACGIH.

NTP: No component of this product present at levels greater than or equal to 0.1% is identified as a known or anticipated carcinogen by NTP.

OSHA: No component of this product present at levels greater than or equal to 0.1% is identified as a carcinogen or potential carcinogen by OSHA.

**Teratogenicity:** No data available

**Reproductive/fertility toxicity:** No data available

**Specific target organ toxicity, single exposure:** No data available

**Specific target organ toxicity, repeated exposure:** No data available

## Section 12: Ecological Information

**12.1 Toxicity:** No data available

**12.2 Persistence and degradability:** No data available

**12.3 Bioaccumulative potential:** No data available

**12.4 Mobility in soil:** No data available

**12.5 Results of PBT and vPvB assessment:** No data available

**12.6 Other adverse effects:** An environmental hazard cannot be excluded in the event of unprofessional handling or disposal.

## Section 13: Disposal Considerations

### 13.1 Waste treatment methods

**Product:** All waste must be handled and disposed according to local, state, and federal regulations. Avoid disposing large volumes in sewer.

**Contaminated packaging:** All waste must be handled and disposed according to local, state, and federal regulations.

Refer to sections 7 and 8 for safe handling guidance.

## Section 14: Transport Information

**UN Number:** Not regulated

**UN Proper shipping name:** Not classified as dangerous in the meaning of transport regulations.

**Transport hazard class(es):** No data available

**Packing group:** No data available

**Environmental hazard:** No data available

**Bulk transport:** No data available

**Special considerations:** No data available

## Section 15: Regulatory Information

To the best of our knowledge, this product contains no substances which, at their given concentrations, are considered hazardous by other regulatory agencies. Refer to section 3.

## Section 16: Other information

This information is based on our present knowledge. While Abraxis, Inc. believes that the data contained herein are factual and the opinions expressed represent a best effort to present accurate information, the data are not to be taken as a warranty or representation for which Abraxis, Inc. assumes legal responsibility. The information shall not be taken as being all-inclusive and is to be used only as a guide. The data are offered solely for the user's consideration, investigation, and verification. These suggestions should not be confused with either state, municipal, or insurance requirements, or with national safety codes and constitute no warranty. Any use of these data and information must be determined by the user to be in accordance with applicable federal, state, and local regulations.

All materials and mixtures may present unknown hazards and should be used with caution. Since Abraxis, Inc. cannot control the methods, volumes, or conditions of use of this product, Abraxis, Inc. shall not be held liable for any damages or losses resulting from the handling or from contact with the product as described herein. An individual technically qualified to handle potentially hazardous chemicals must supervise the use of this material. This product is sold for research use only. It is not for any human or animal therapeutic or clinical diagnostic use.

**Date this SDS was prepared:** 5/20/2016

**Version:** 2

**Changes from previous version:** Abraxis, LLC changed to Abraxis, Inc.